

Figura 8.6. Conexión del motor en estrella.

MARCA COMERCIAL		
MOTOR	FRECUENCIA	NORMA CONSTRUCCIÓN
3 $\sim$	50 Hz	IEC 34-1
TENSIÓN DE FTO.		INTENSIDAD NOMINAL
400/230 V		1,4/2,4 A
CONEXIONADO		POTENCIA NOMINAL
		0,37 kW / 0,5 CV
GRADO DE PROTECCIÓN		FACTOR DE POTENCIA
IP 54		$\text{Cos}\varphi = 0,65$
		VELOCIDAD NOMINAL
		1000 r.p.m.

*Figura 8.7. Placa de características*



Figura 8.8. Conexión del motor en triángulo



Figura 8.9. Conexión del motor en estrella o triángulo



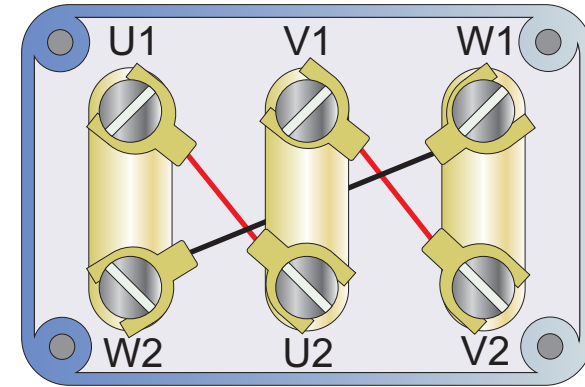
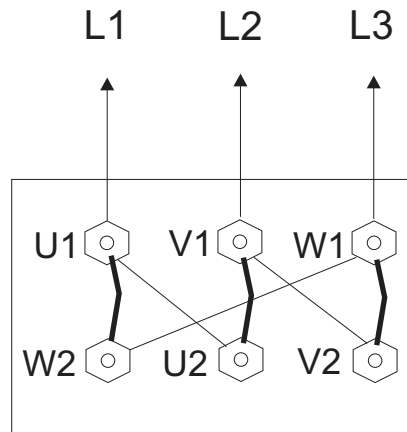
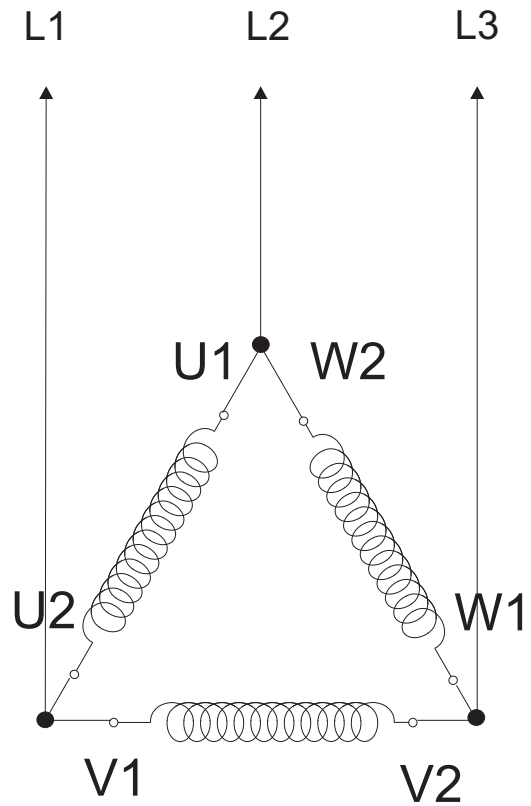

*Figura 8.10. Relaciones entre conexión estrella y triángulo.*

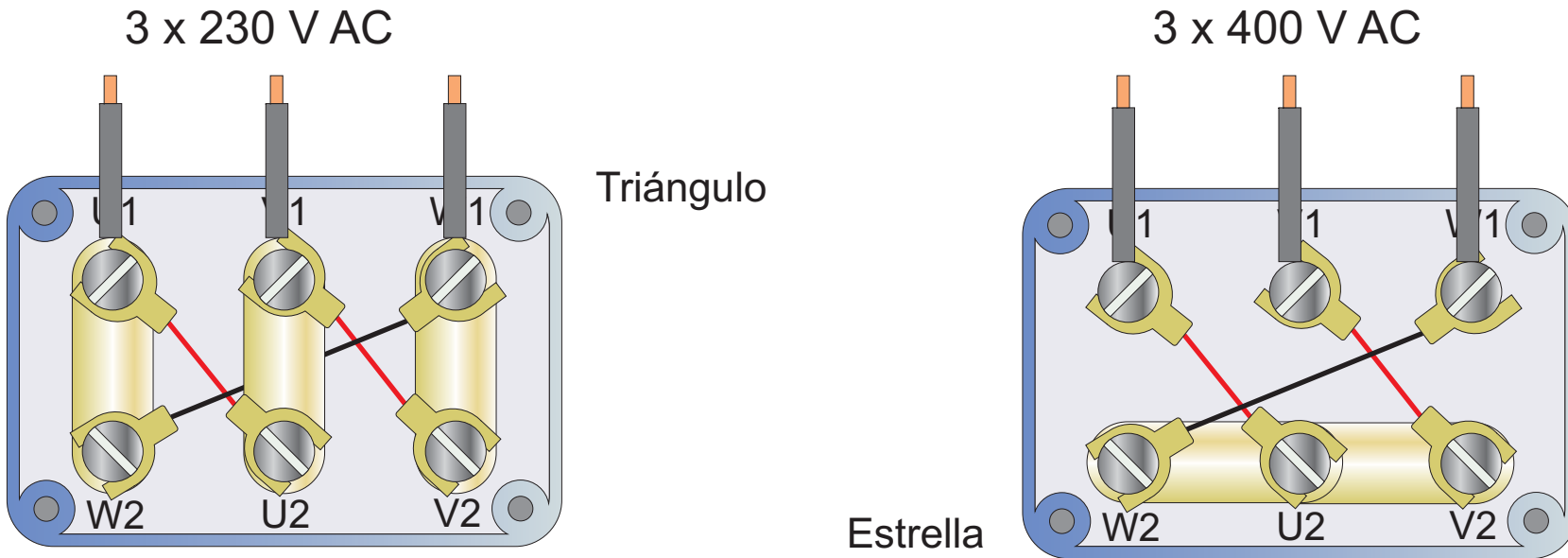
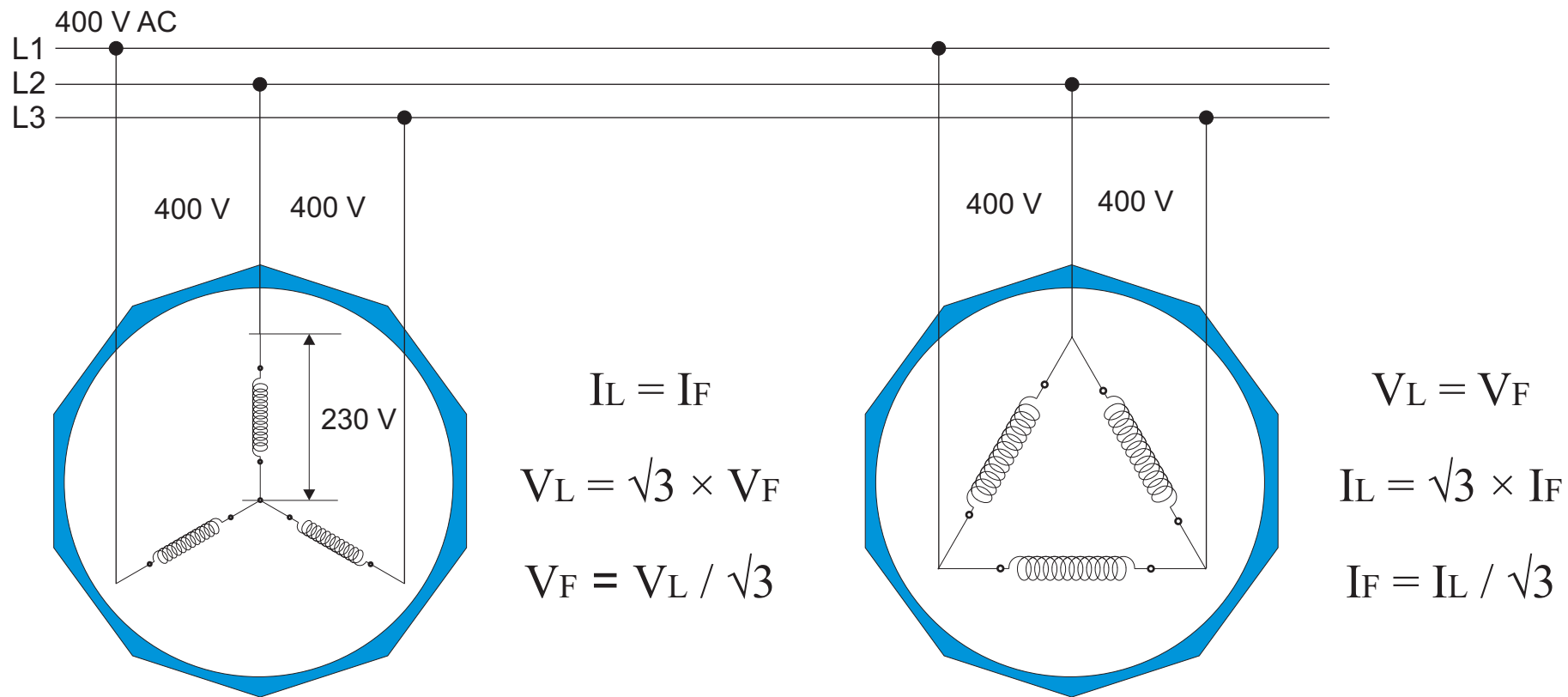
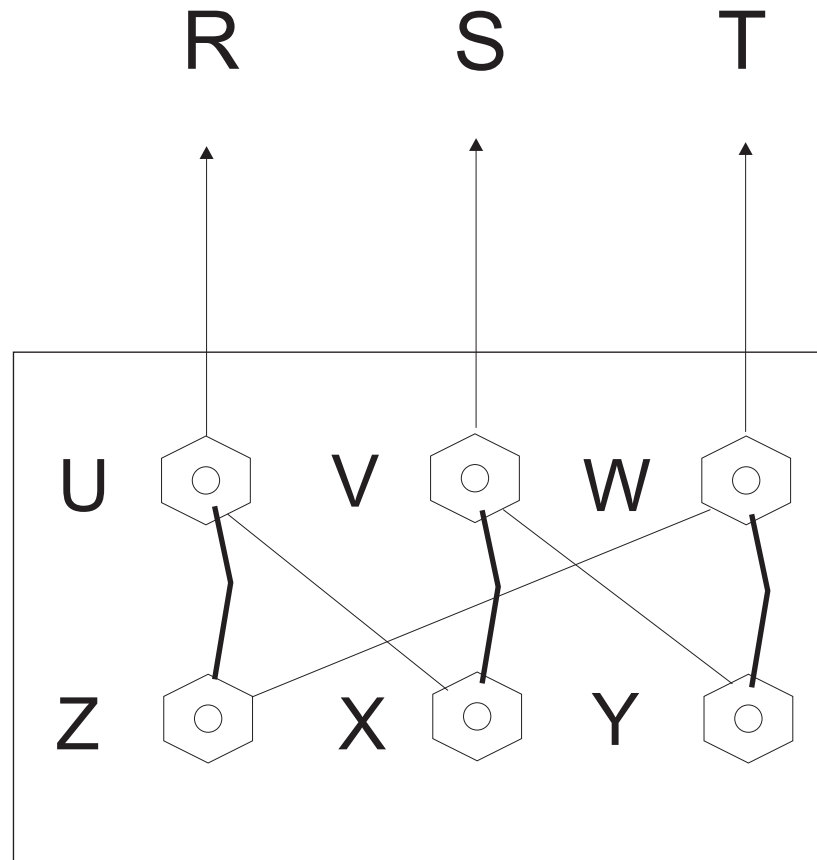

*Figura 8.11.  
Simbología antigua.*



Figura 8.12. Puesta en marcha de un motor trifásico sin, y con protecciones.



Arranque directo

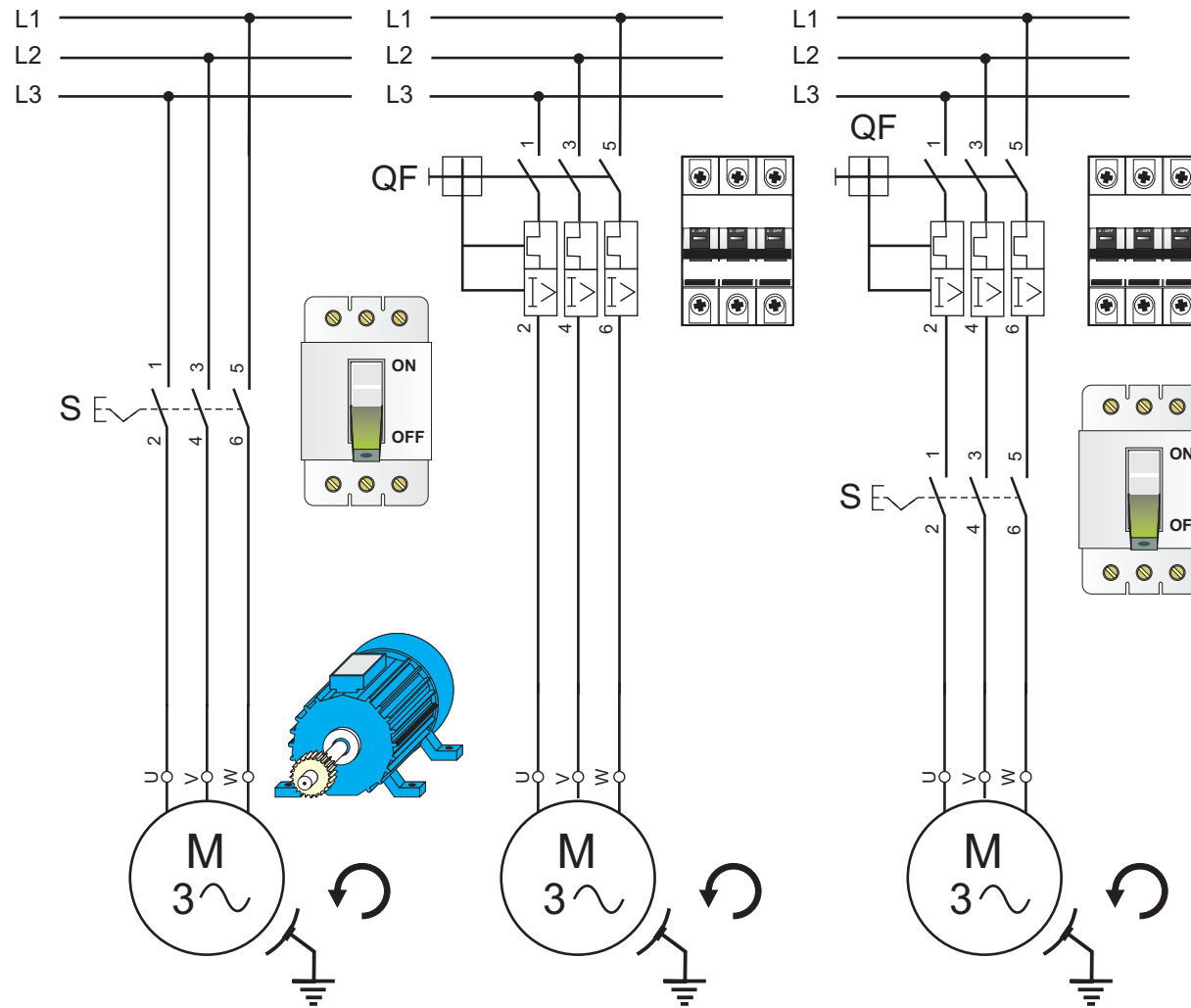
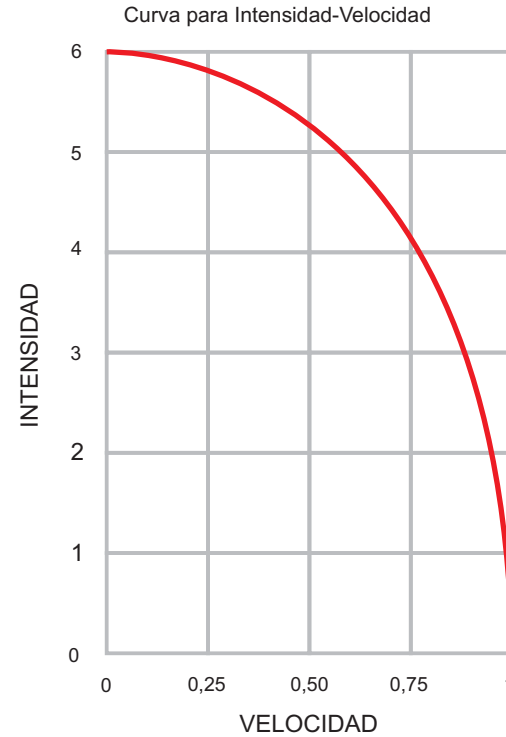
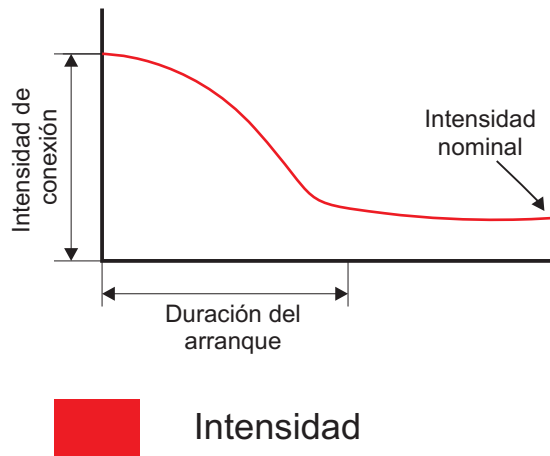
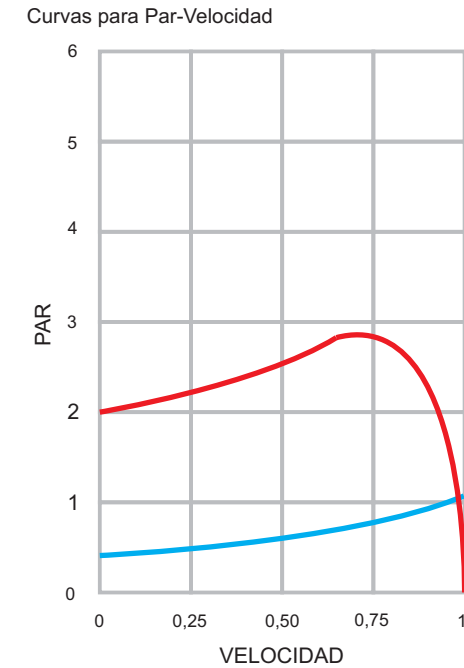

Arranque con carga  $I = 6 \times I_n$

Velocidad nominal  $I = I_n$

Figura 8.13. Curvas características del arranque directo.





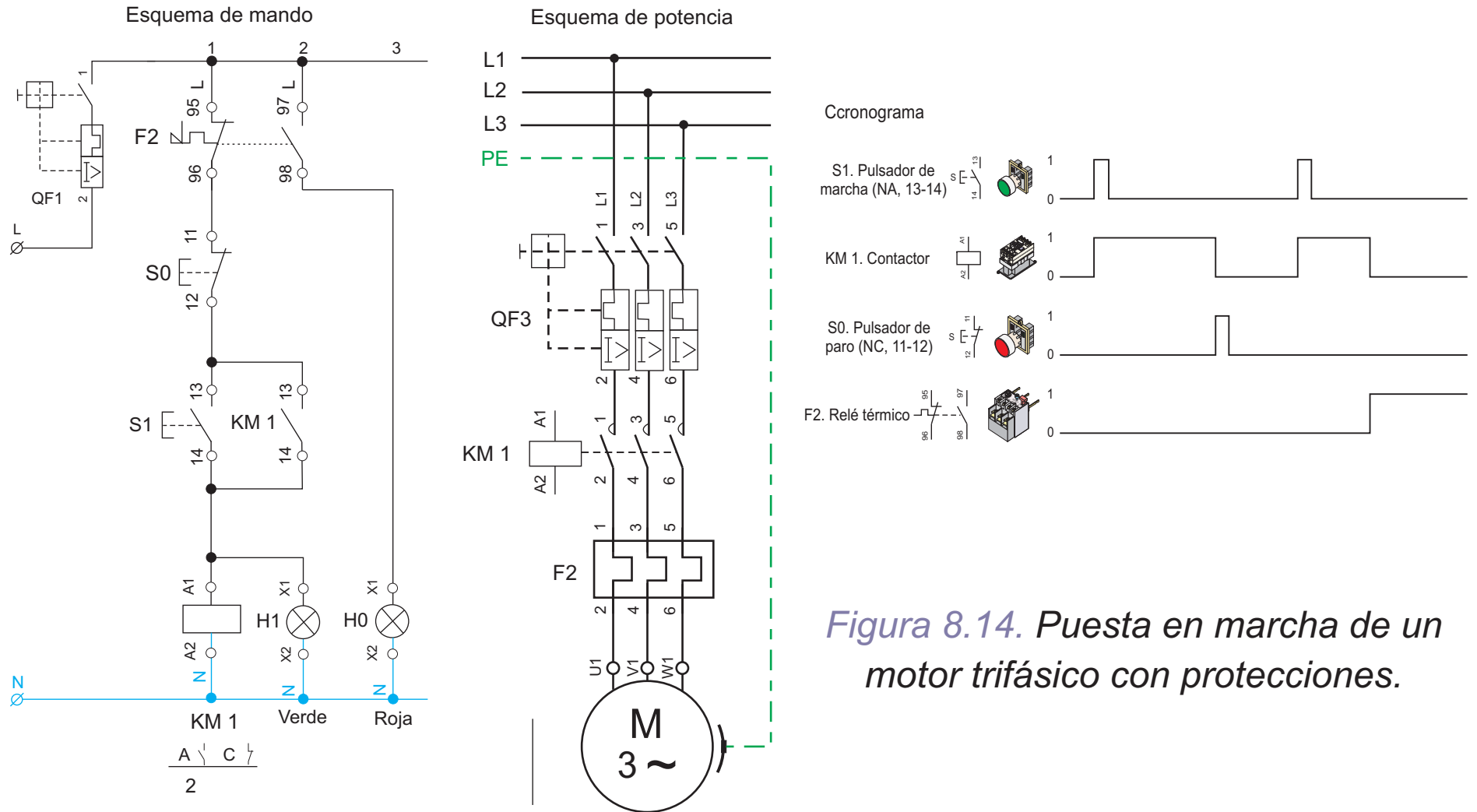



Figura 8.15. Interruptor guardamotor compacto.





Figura 8.16. Inversión de sentido de giro de un motor trifásico con

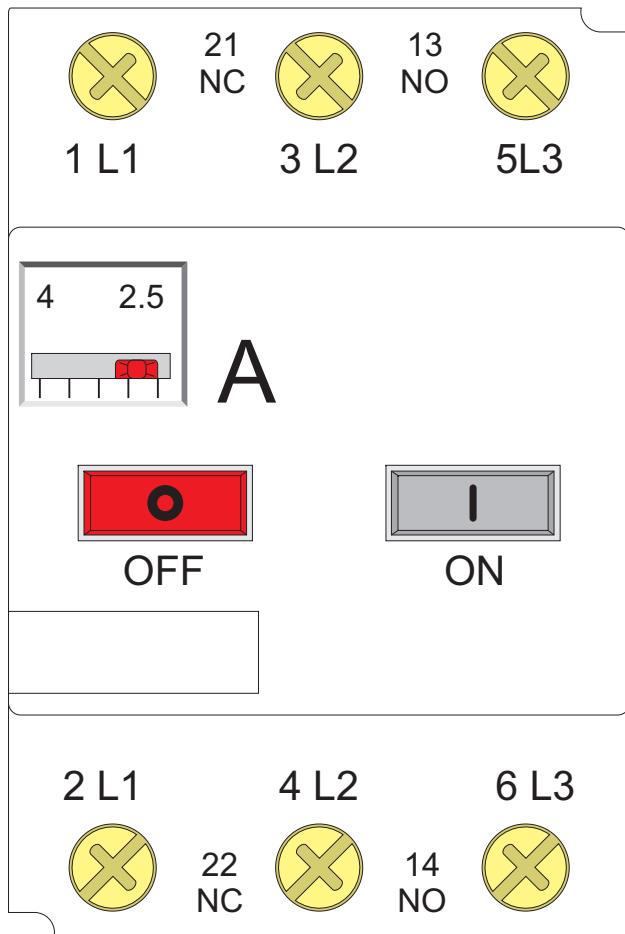
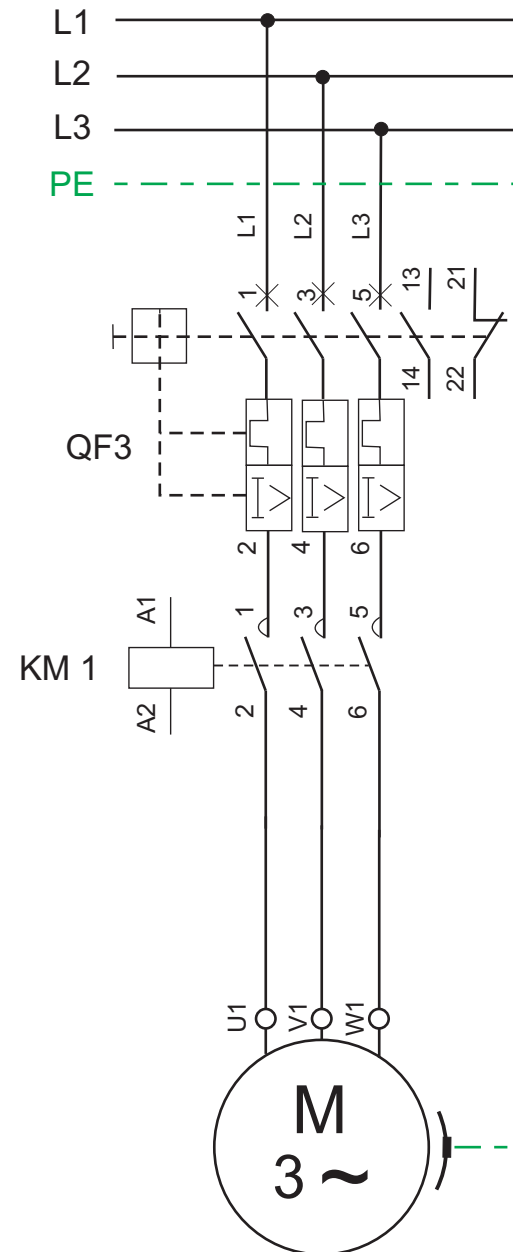

Figura 8.17. Inversión de sentido de giro de un motor trifásico.



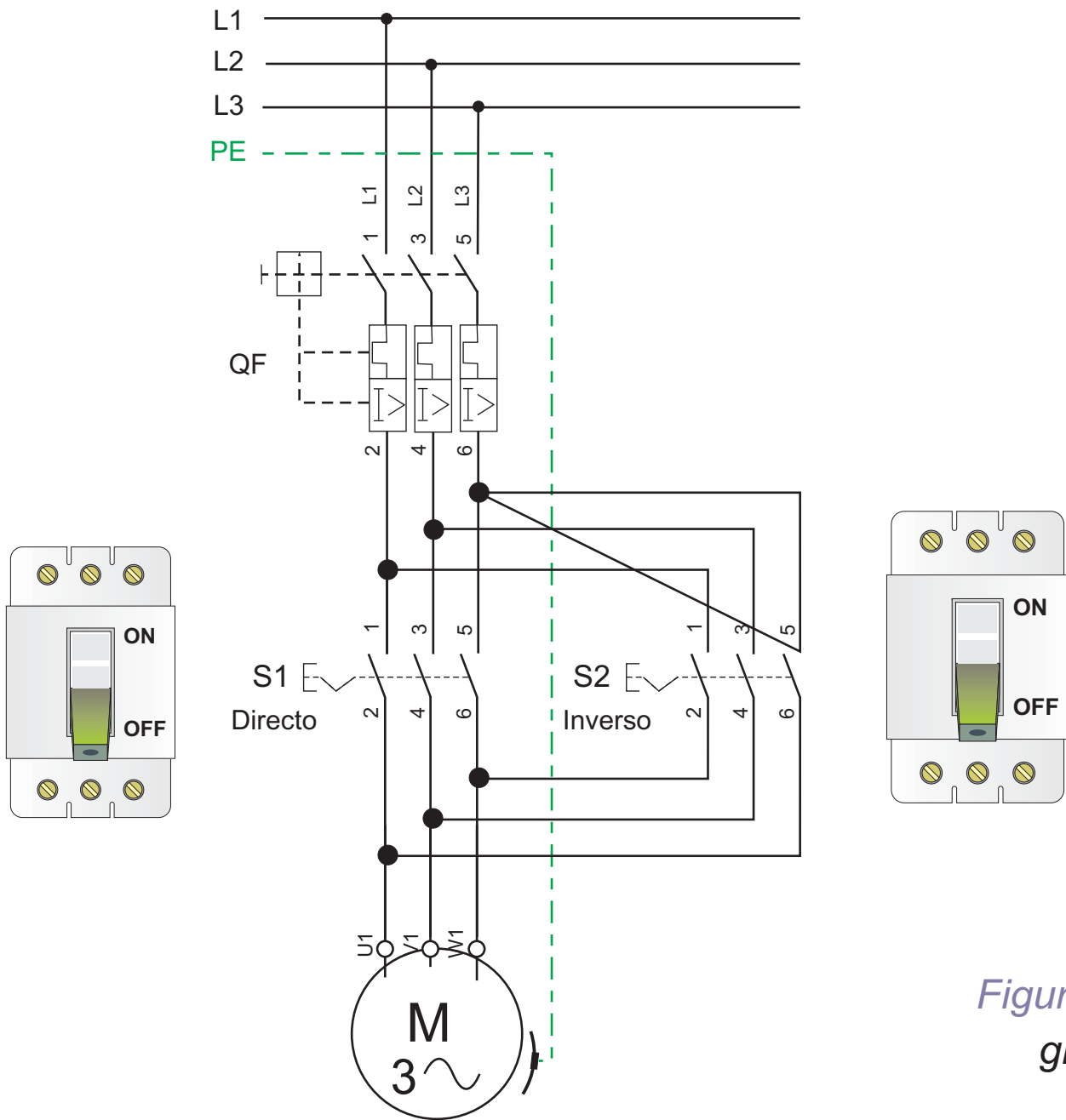

Figura 8.18. Automatismo para la inversión de sentido de giro

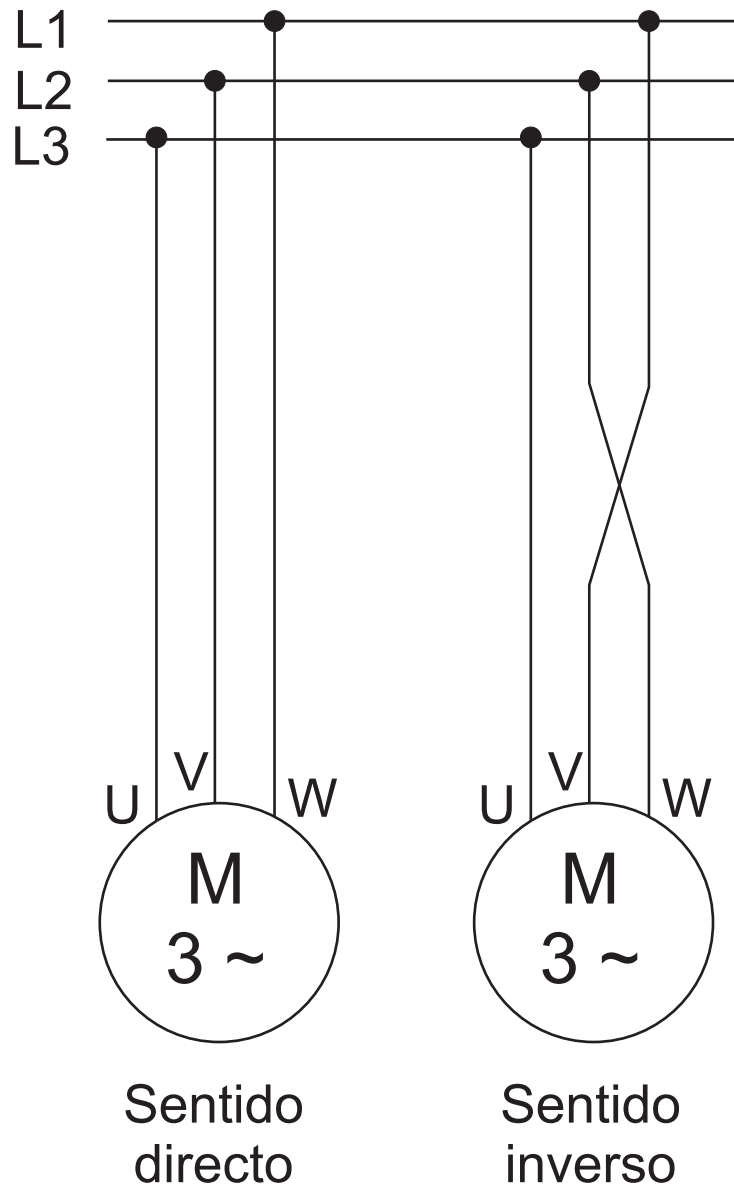
Cronograma



Figura 8.18. Cronograma.

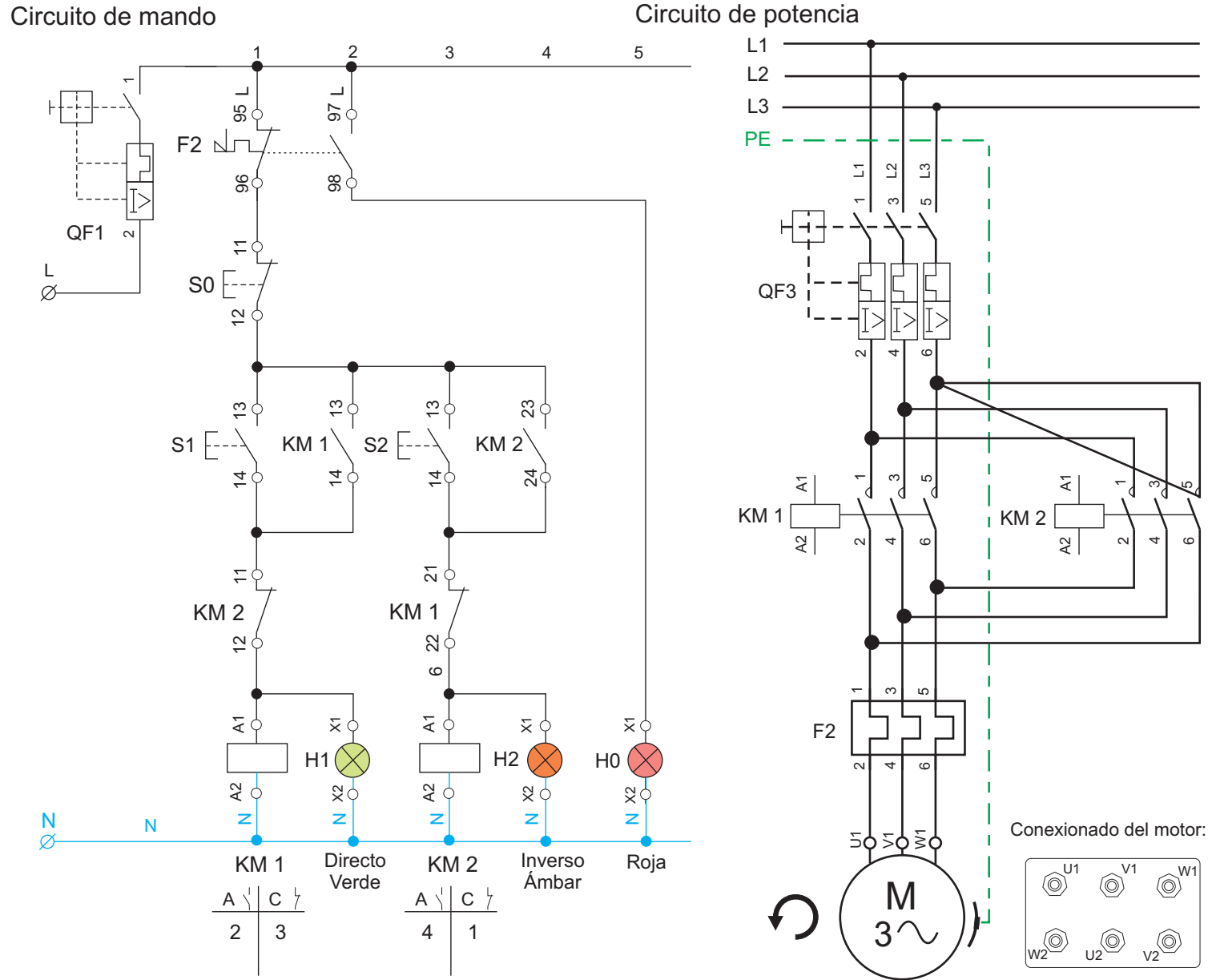



*Figura 8.19. Enclavamientos eléctricos usados en la inversión de sentido de giro.*

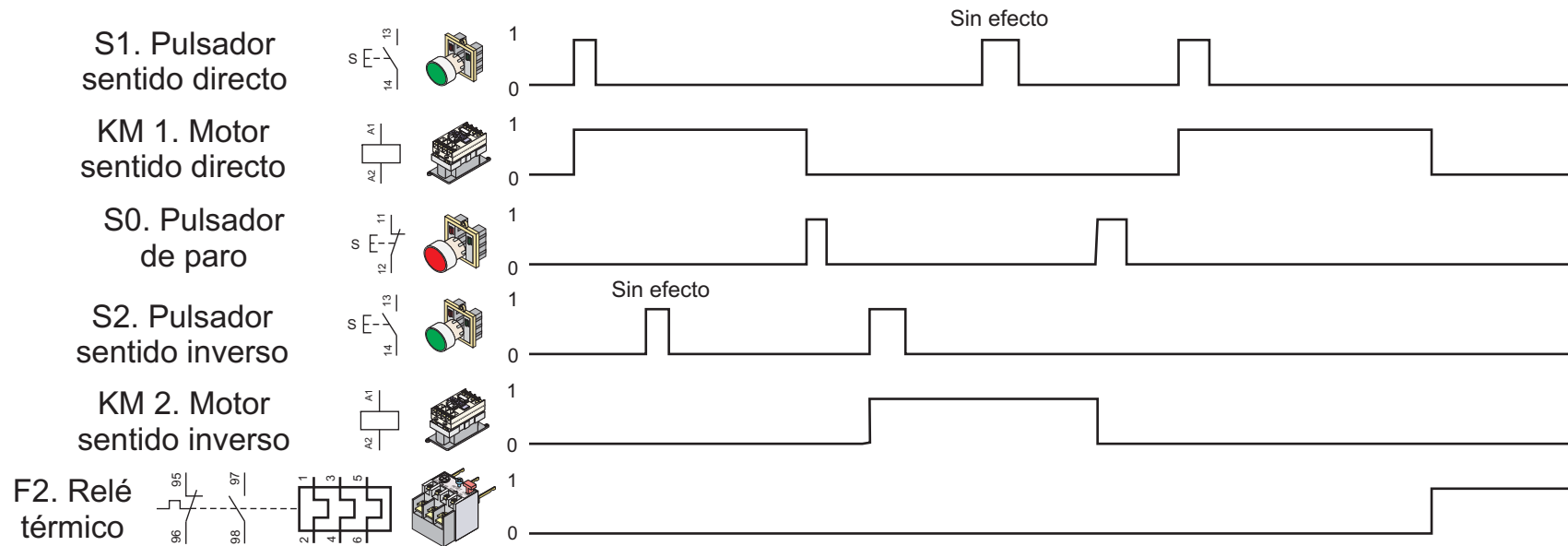
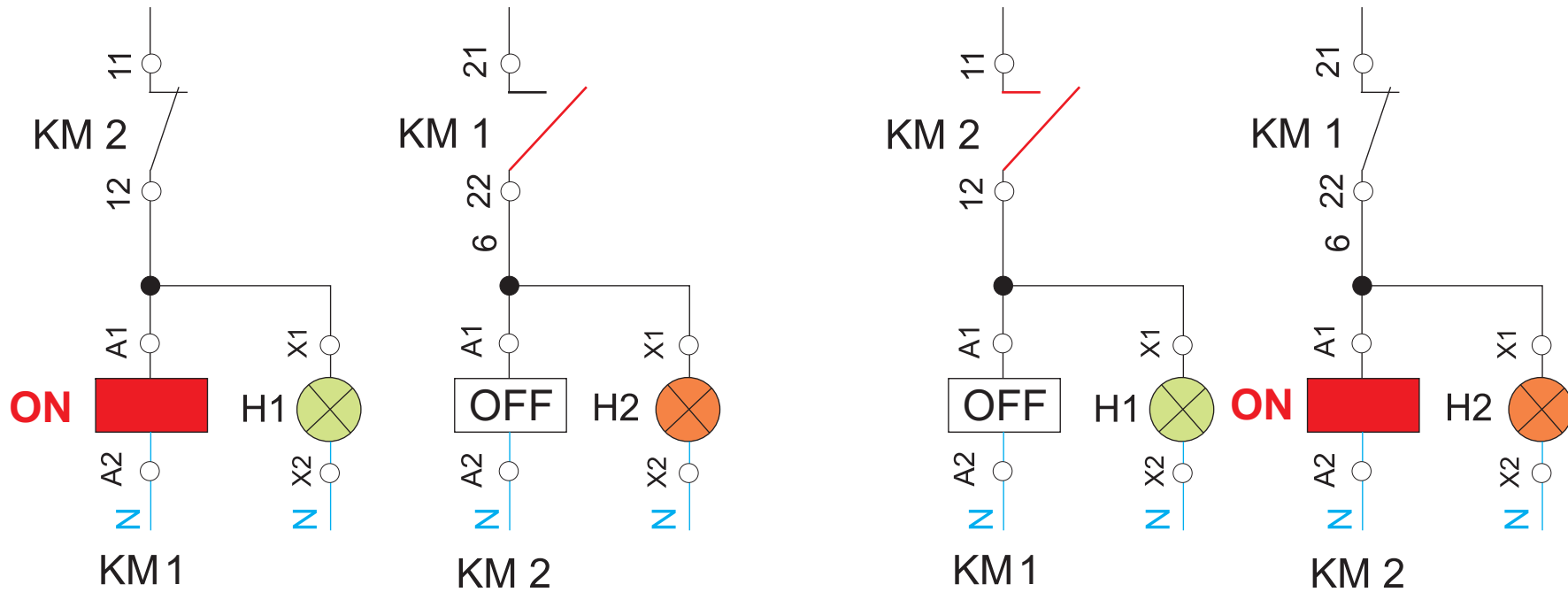

Figura 8.20. Arranque estrella-triángulo.



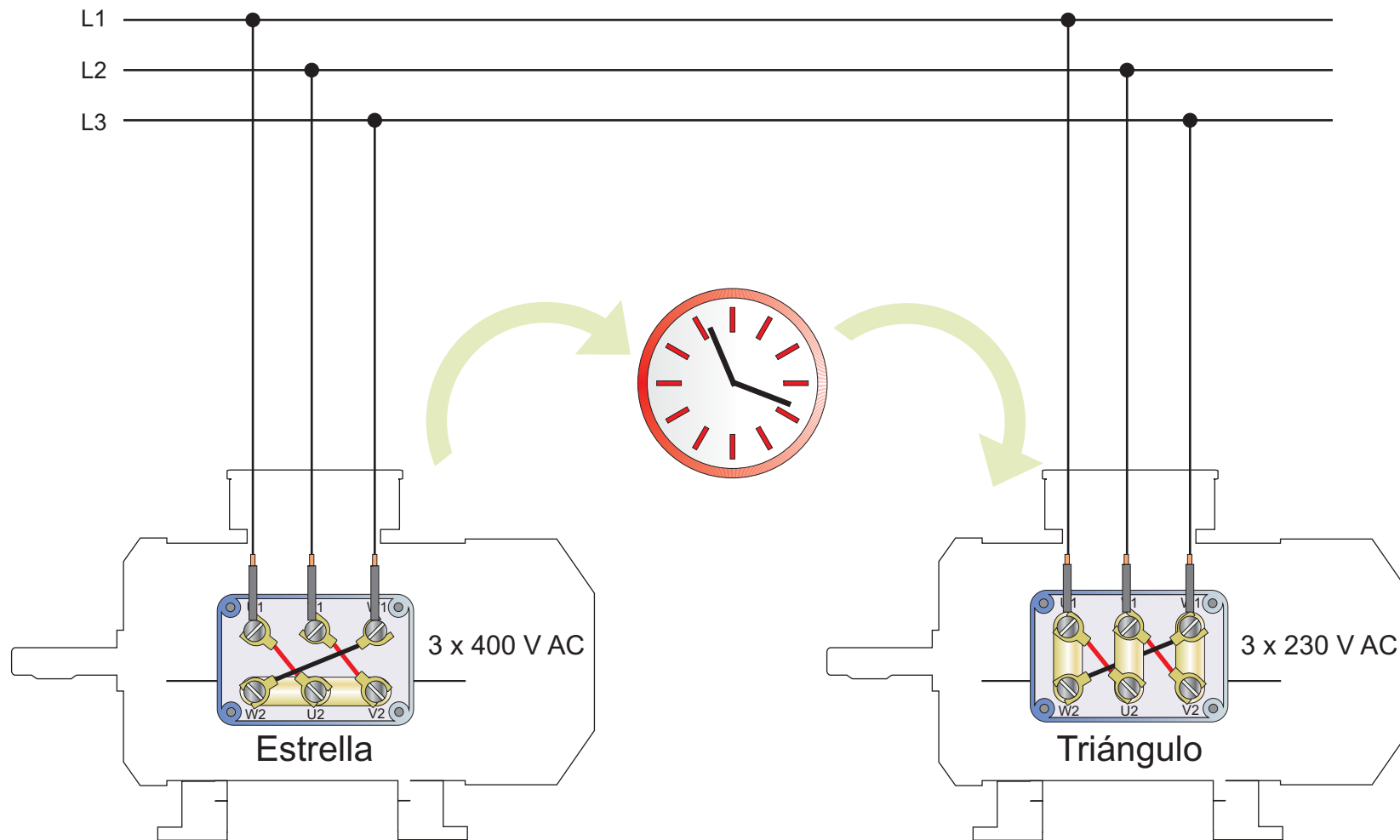

Figura 8.21. Conmutador estrella-triángulo.

Esquema de mando



Figura 8.22. Esquema de mando del arranque estrella-triángulo

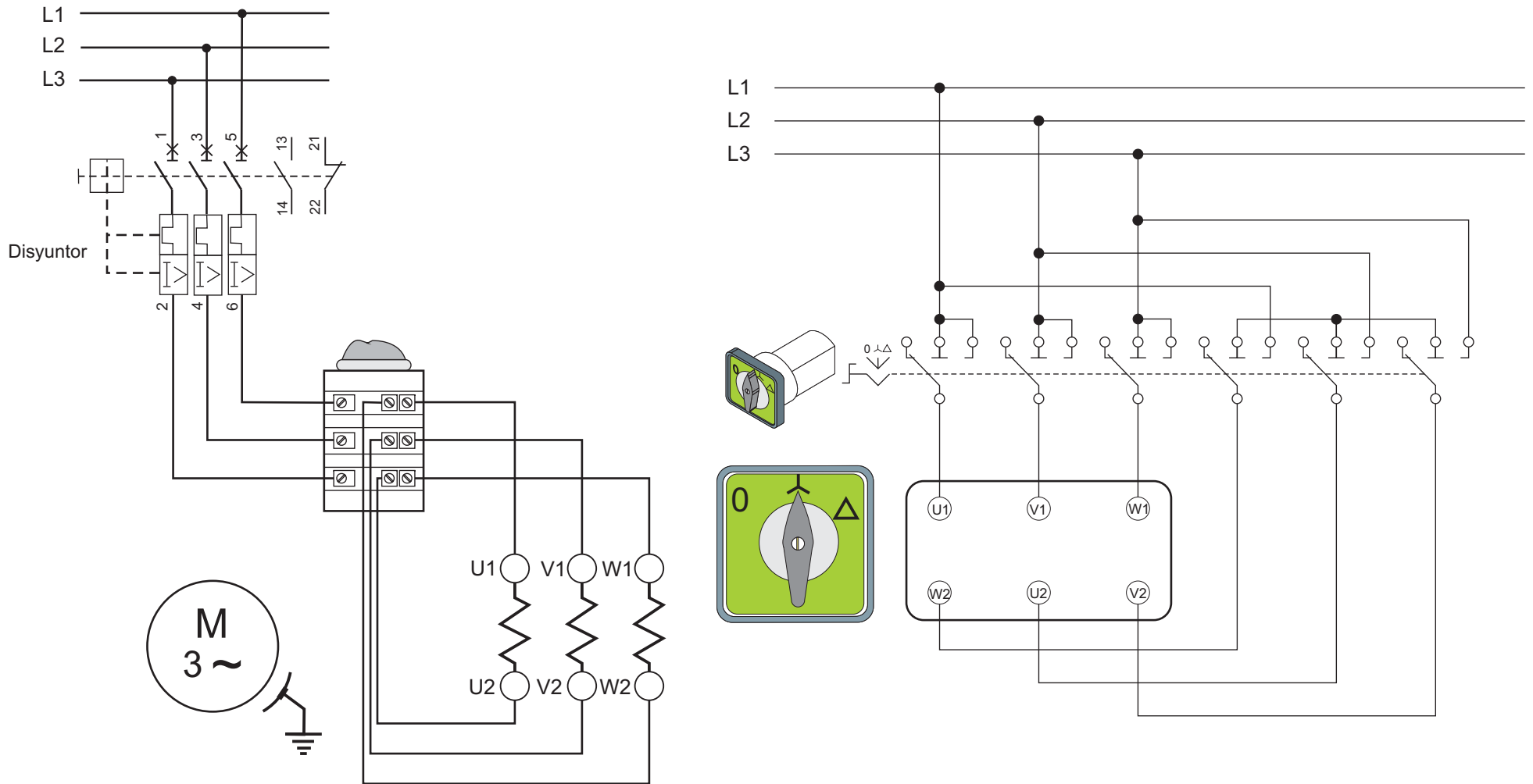

- Arranque directo
- Arranque estrella -triángulo

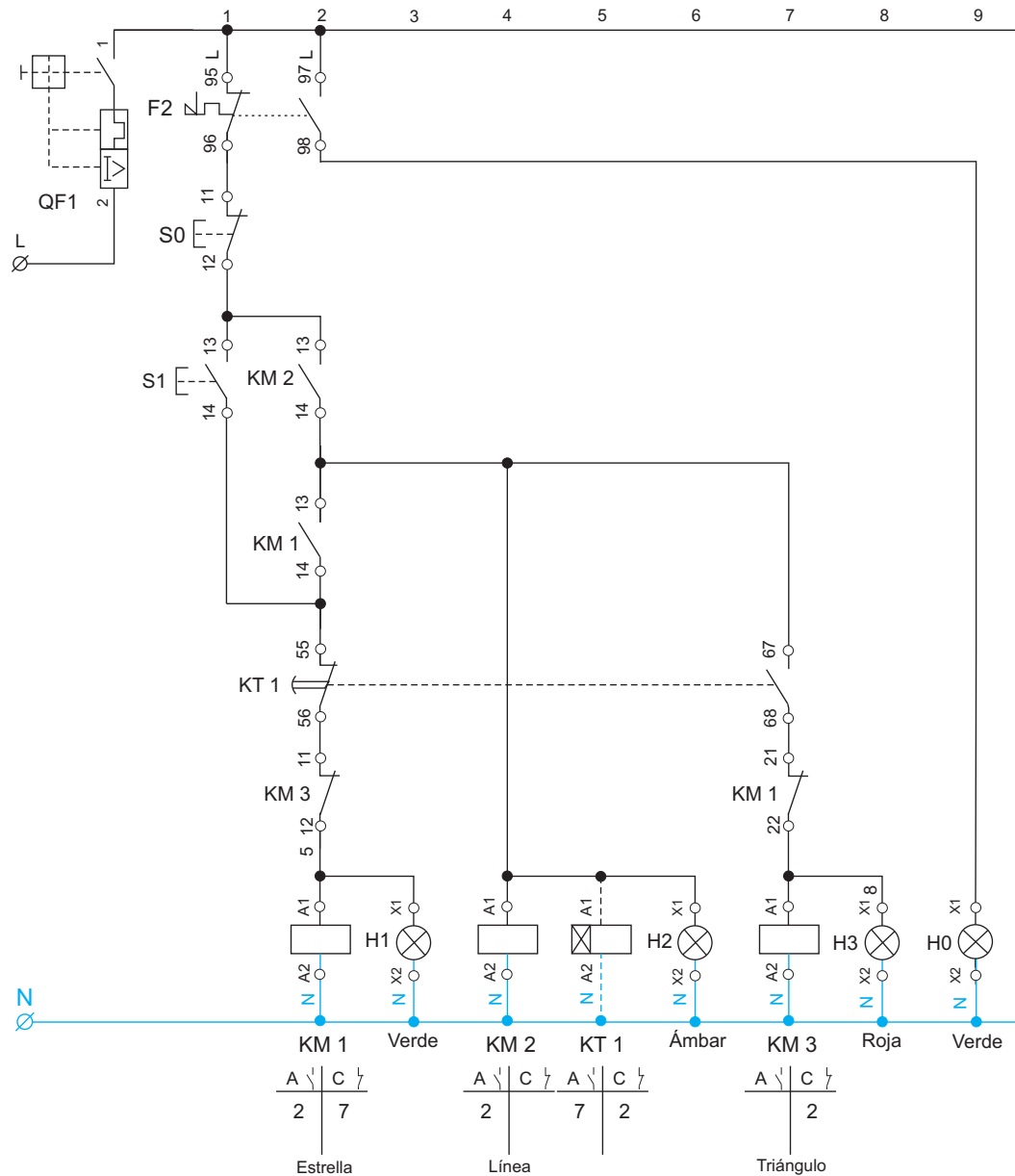
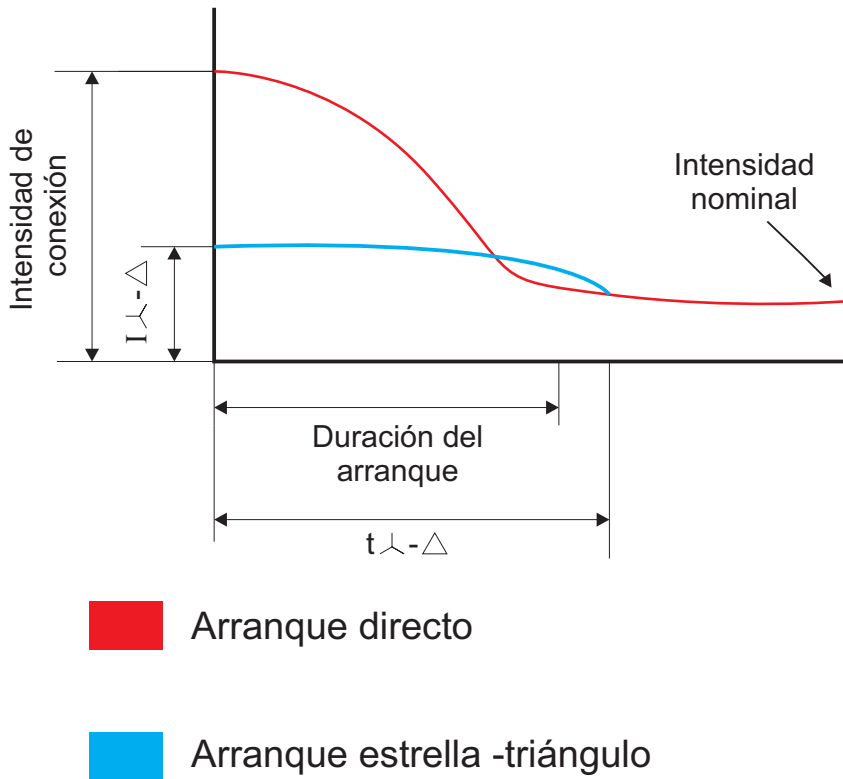
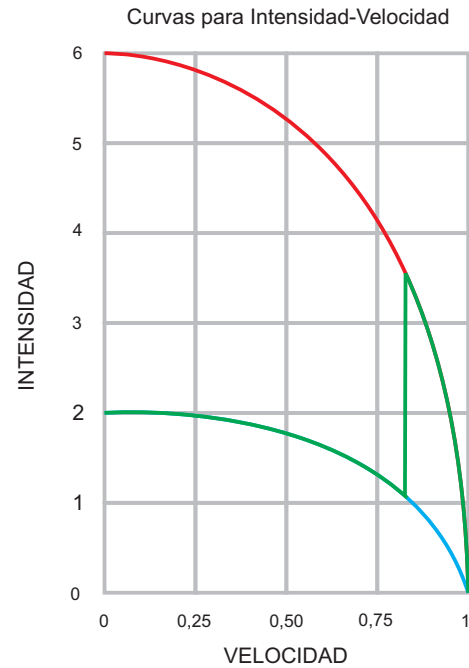

- Intensidad en estrella
- Intensidad en triángulo
- Arranque

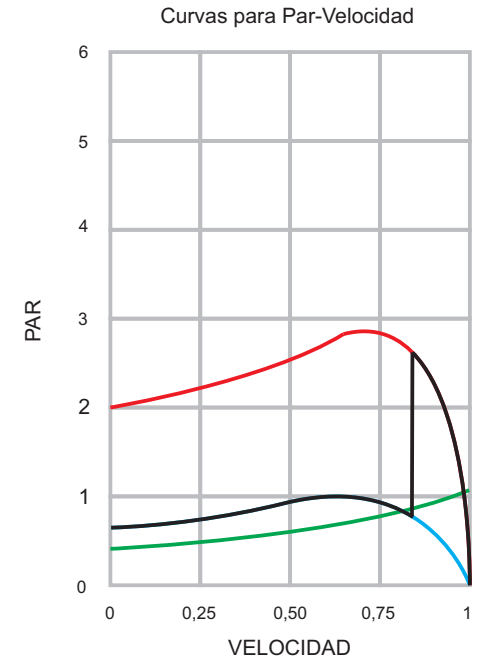

- Par motor en triángulo
- Par motor en estrella
- Par resistente
- Arranque

Figura 8.23. Curvas del arranque Y-D.

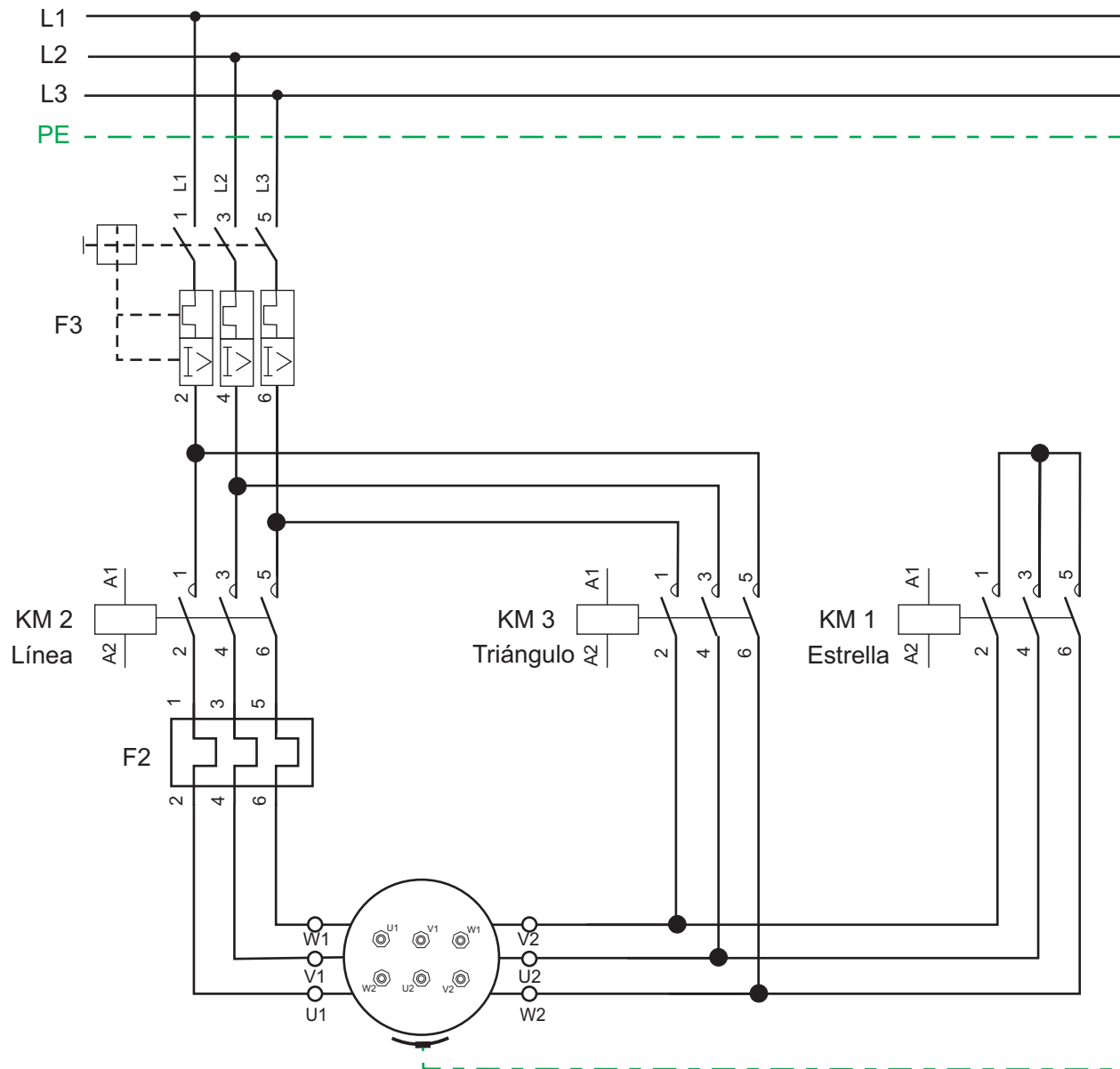

*Figura 8.24.  
Esquema de potencia del arranque estrella-triángulo.*

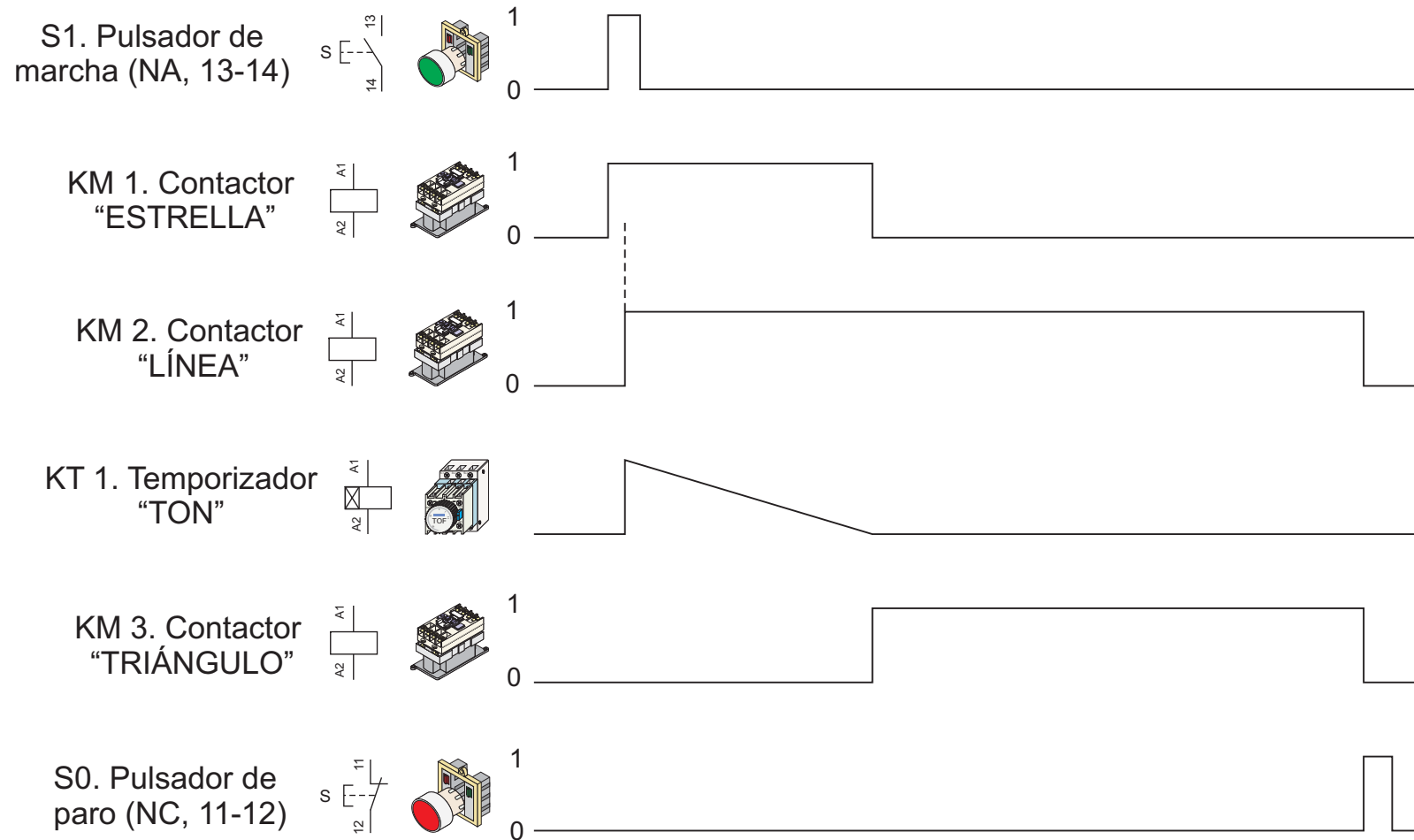

*Figura 8.25. Cronograma del arranque estrella-triángulo.*



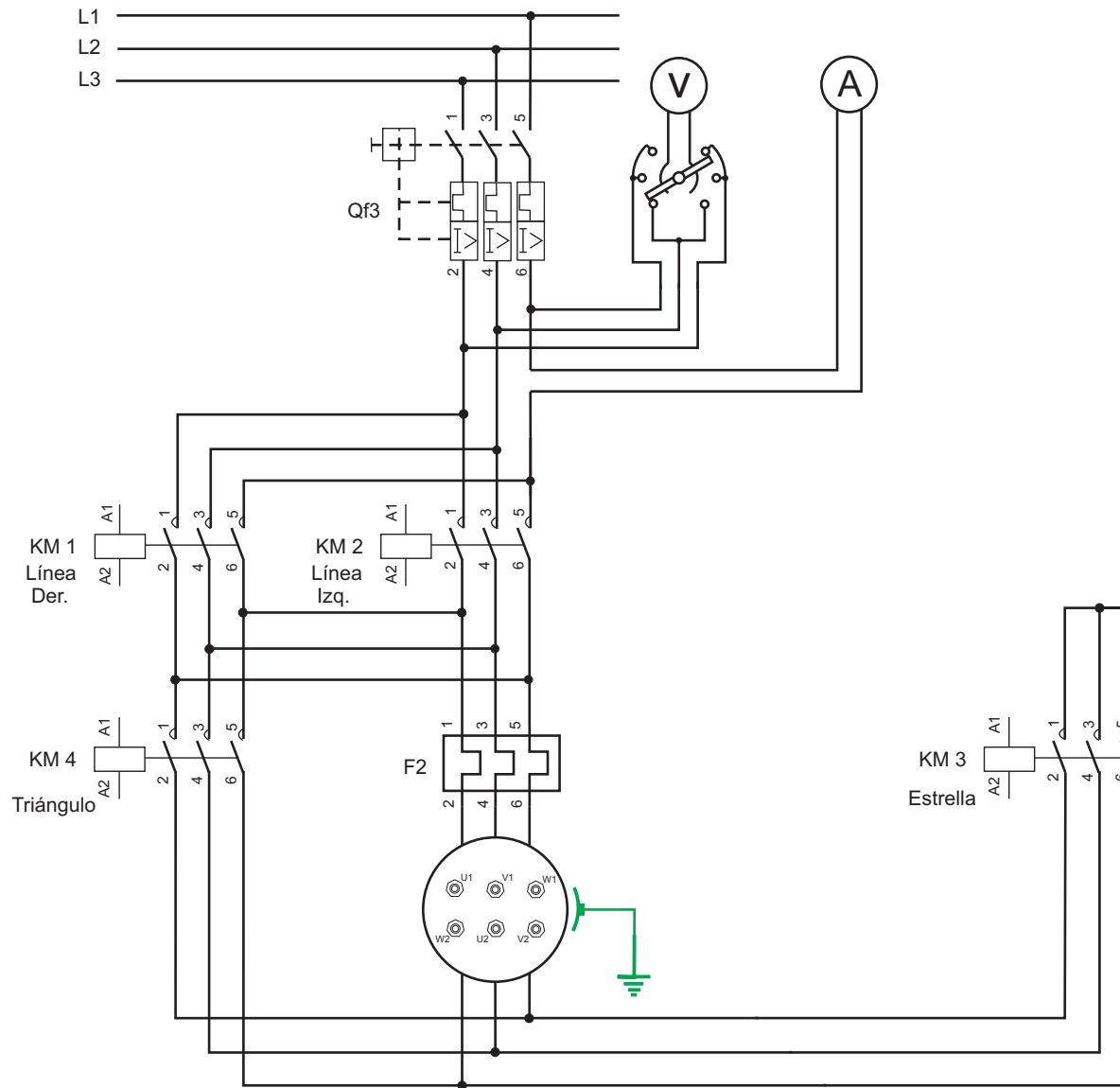

*Figura 8.27. Esquema de potencia del arranque estrella-triángulo con inversión.*



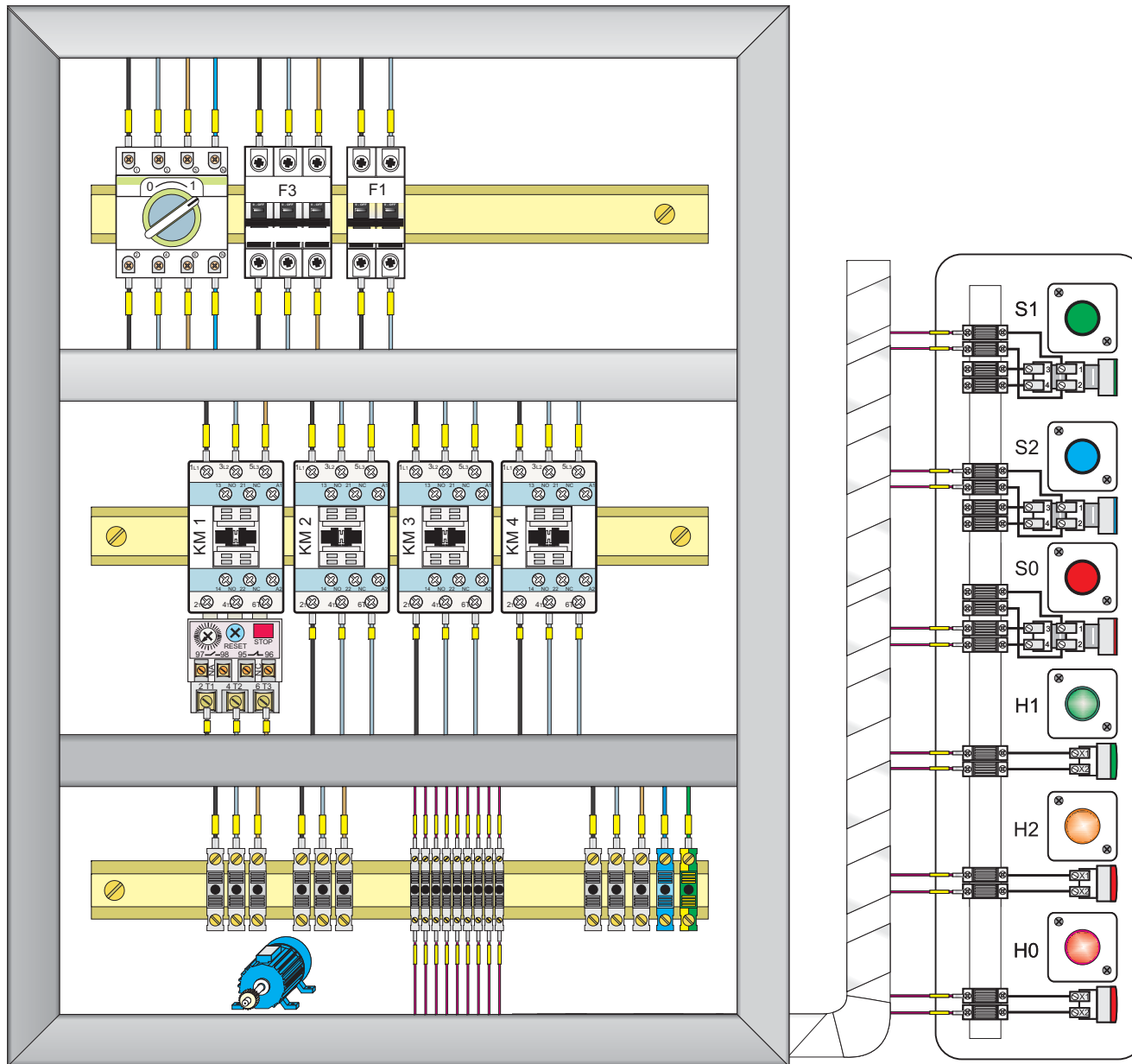

*Figura 8.28.  
Mecanismos a modo  
de ejemplo de un  
cuadro eléctrico para el  
circuito estrella-  
triángulo con inversión.*





Figura 8.29. Esquema de un arranque por eliminación de resistencias en cuatro fases.



*Figura 8.30. Curvas del arranque con un sólo grupo de resistencias.*

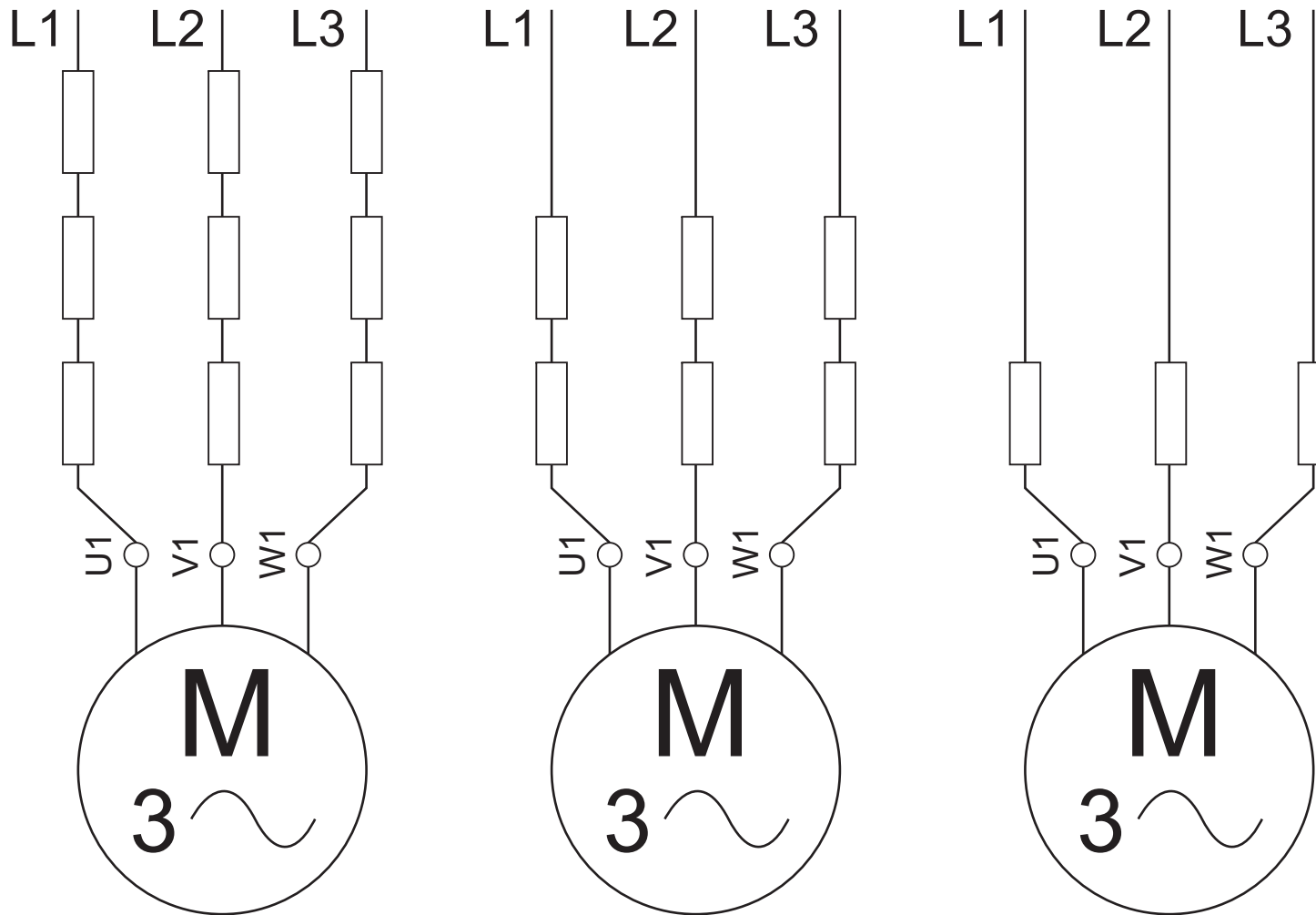
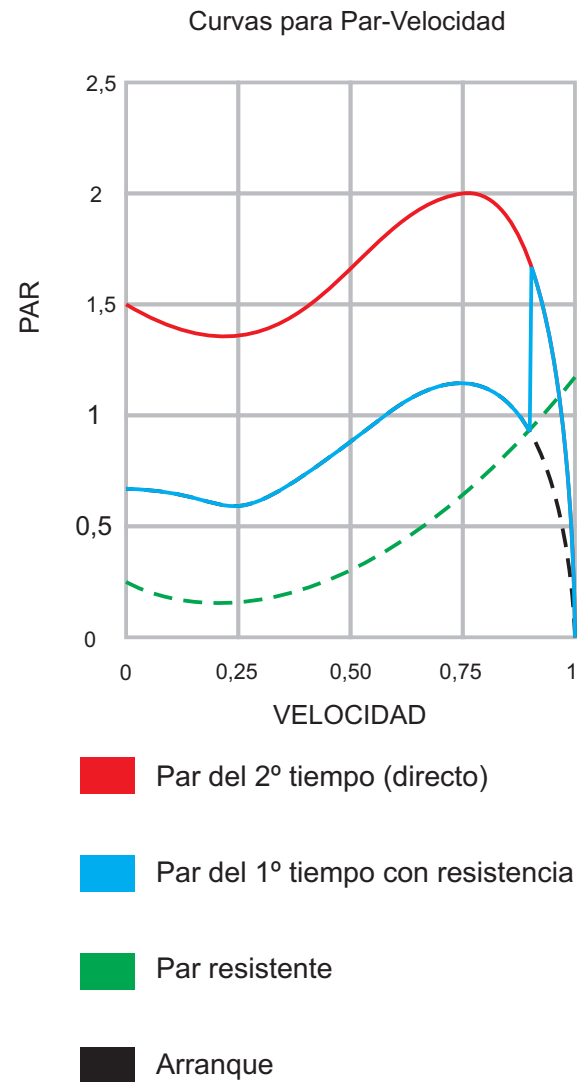
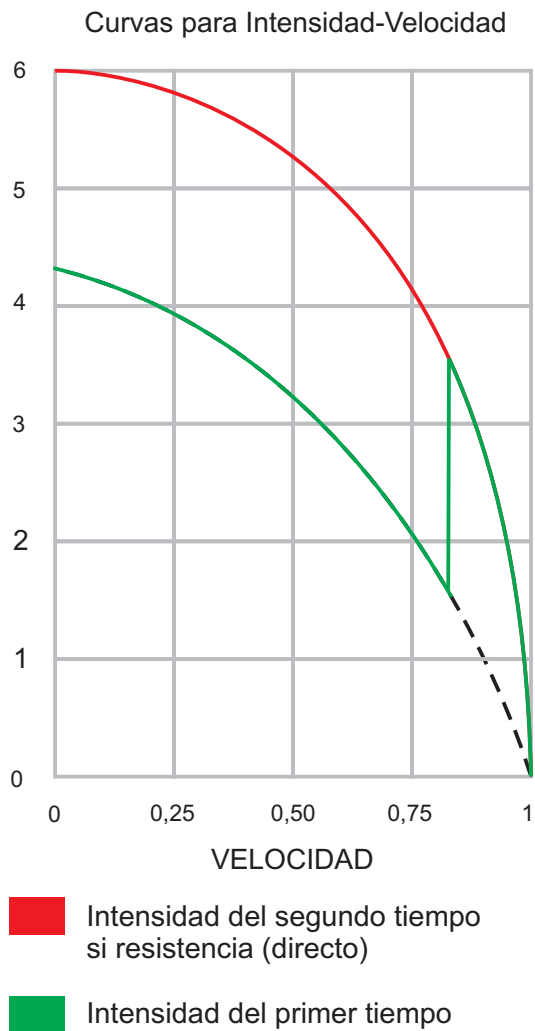

Figura 8.31.  
Esquema de mando  
para el arranque en  
tres fases.





Figura 8.32. Esquema de potencia para el arranque en tres fases.

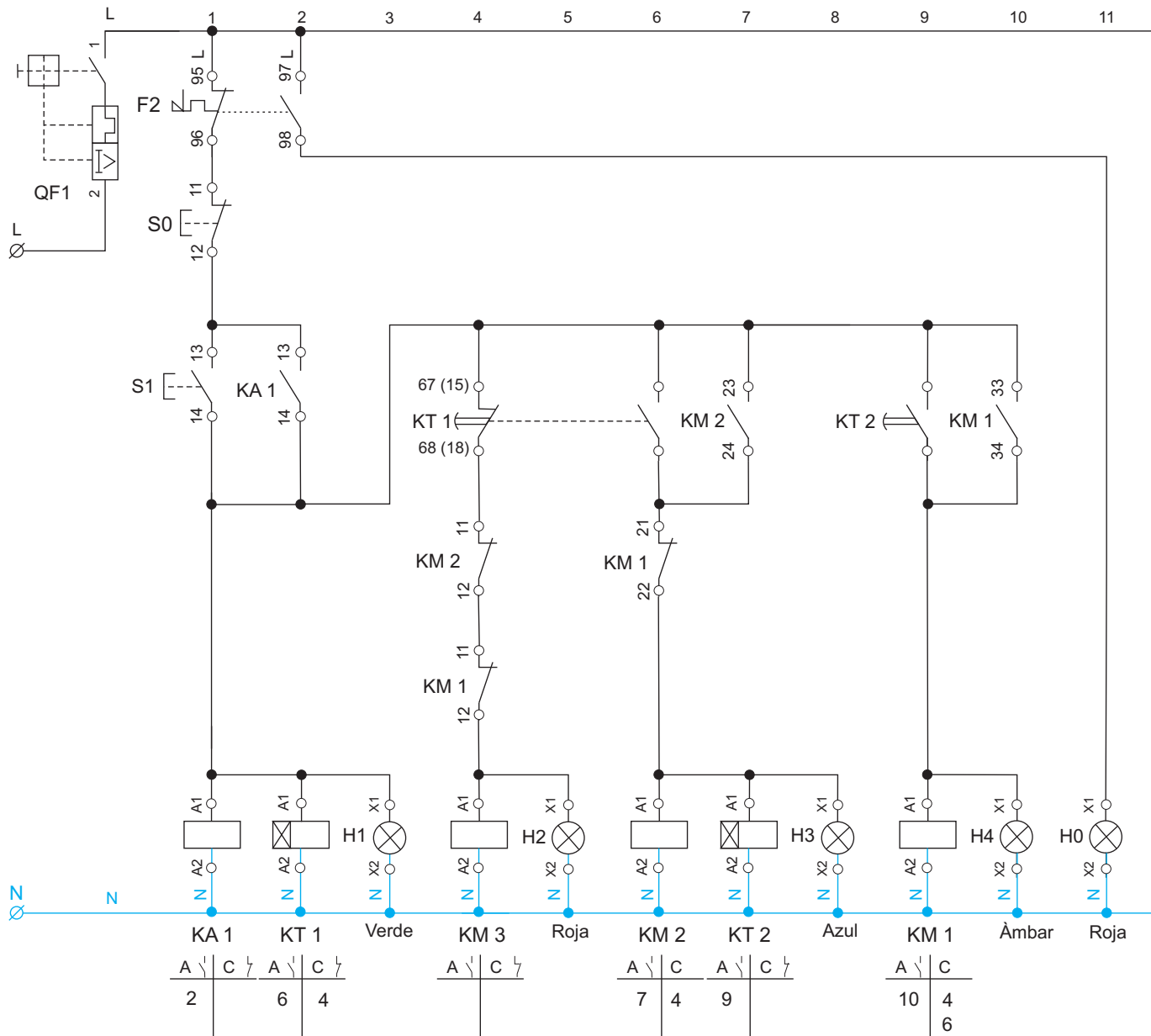

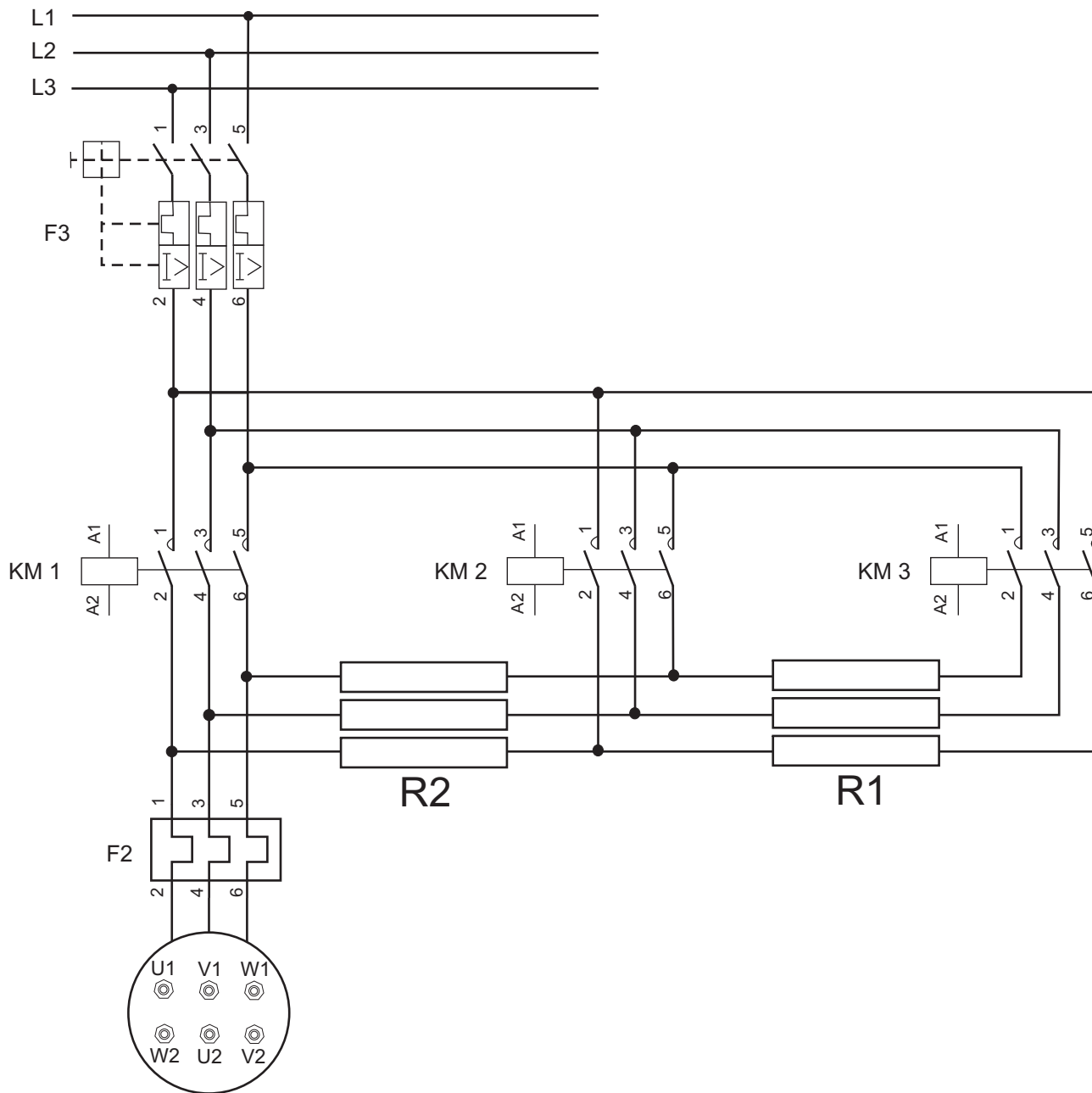
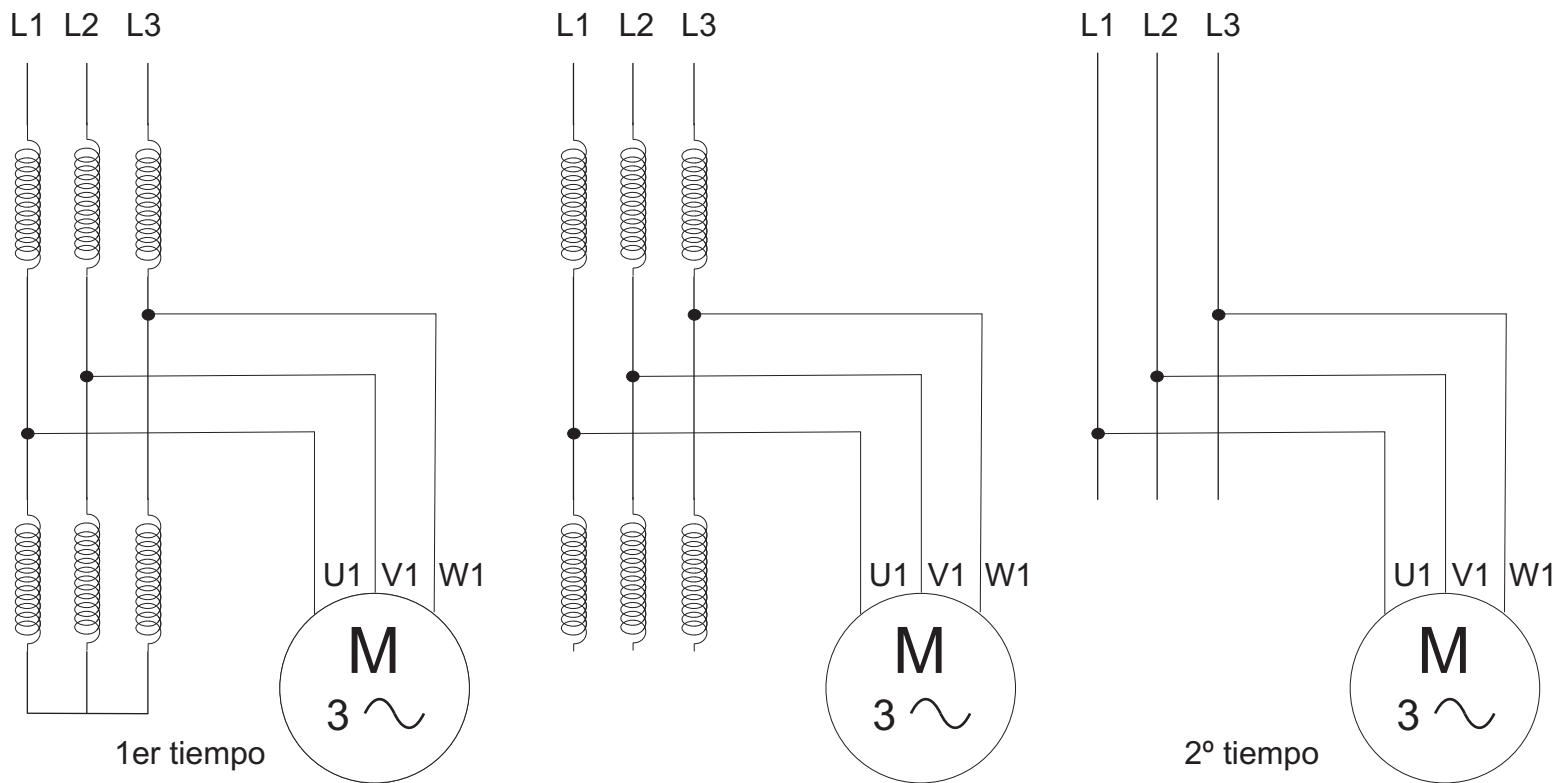

Primera fase. El autotransformador se conecta en estrella. La tensión de arranque es reducida (y controlada).

Segunda fase. La estrella se abre. Las bobinas se conectan en serie con el motor durante un instante.

Tercera fase. El motor queda alimentado de forma directa. El autotransformador se anula del circuito.

Figura 8.33. Esquema de las fases en el arranque.



Figura 8.34. Curvas del arranque.



*Figura 8.35. Símbolos multifilar y unifilar del autotransformador.*



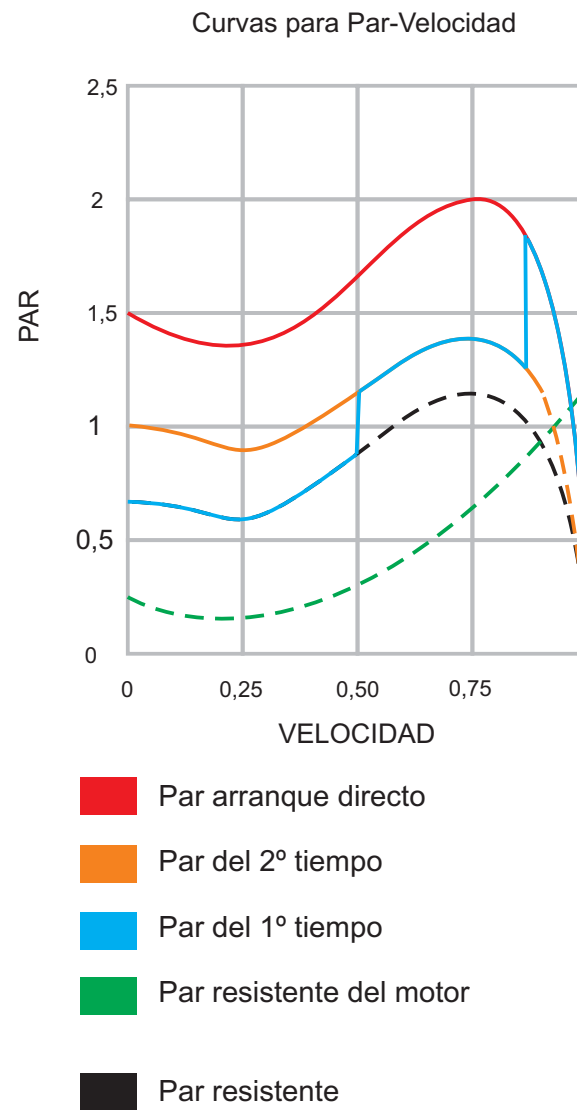
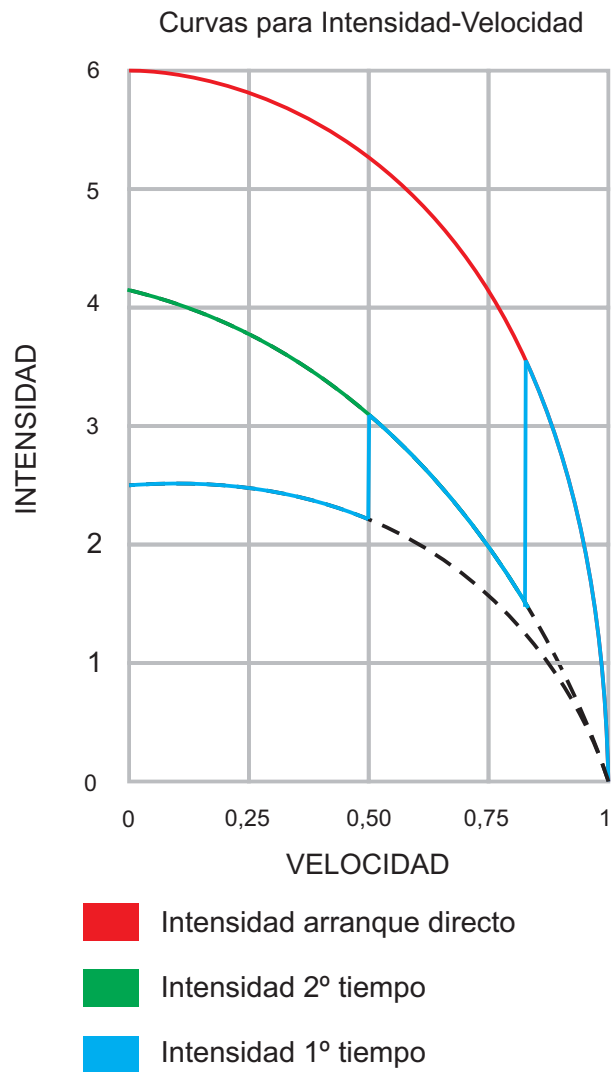
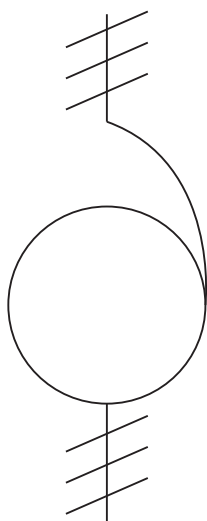
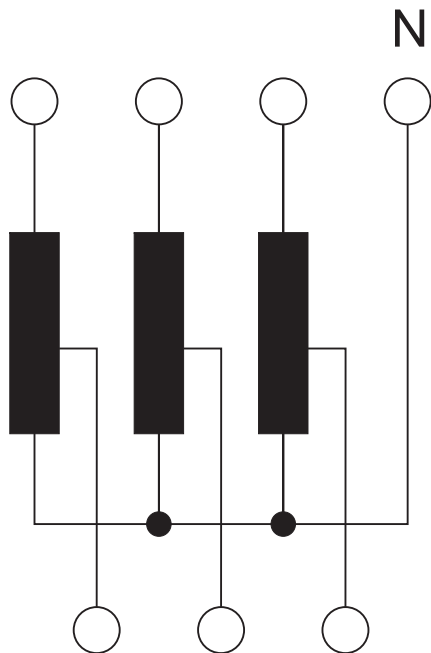

Figura 8.36.  
Esquema de mando.





Figura 8.37.  
Esquema de potencia.

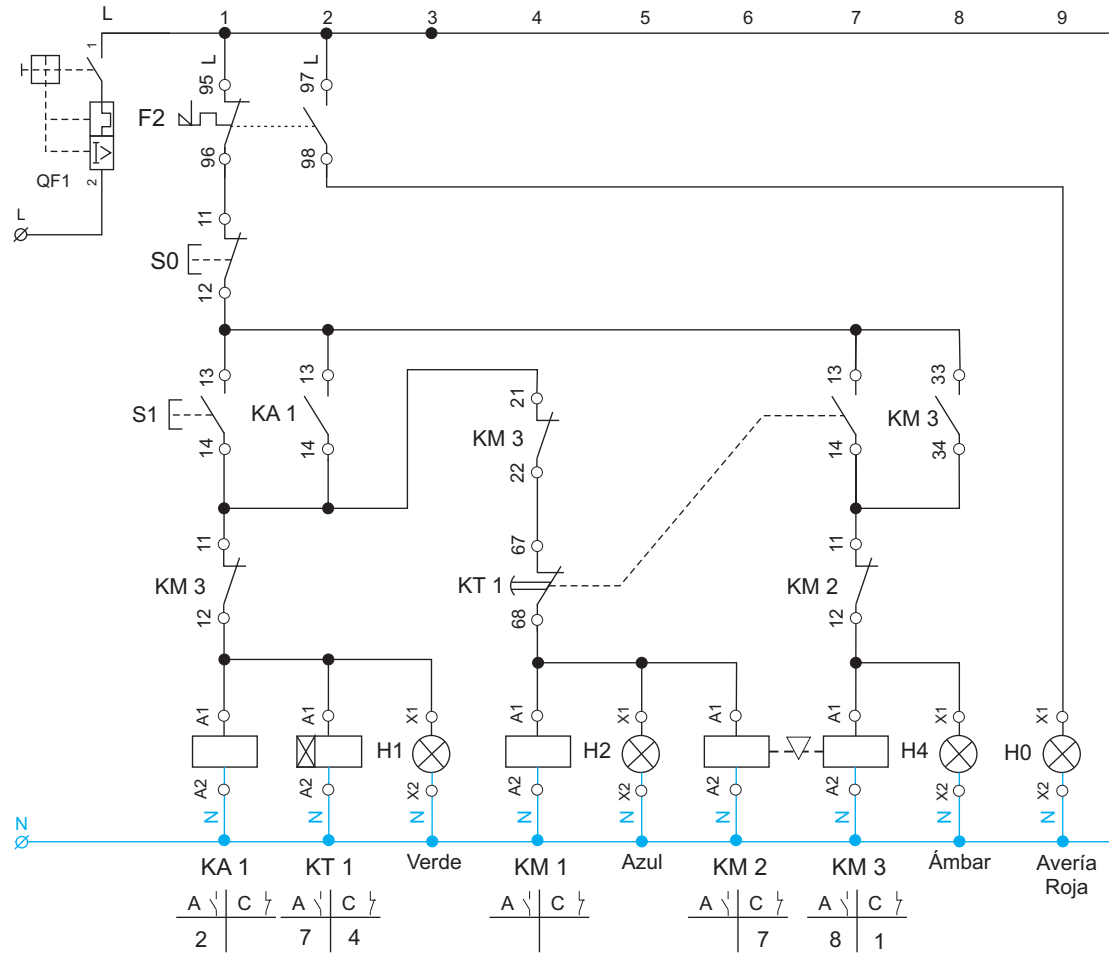

*Figura 8.38. Diagrama de la tensión de salida y esquema de bloques del arrancador.*



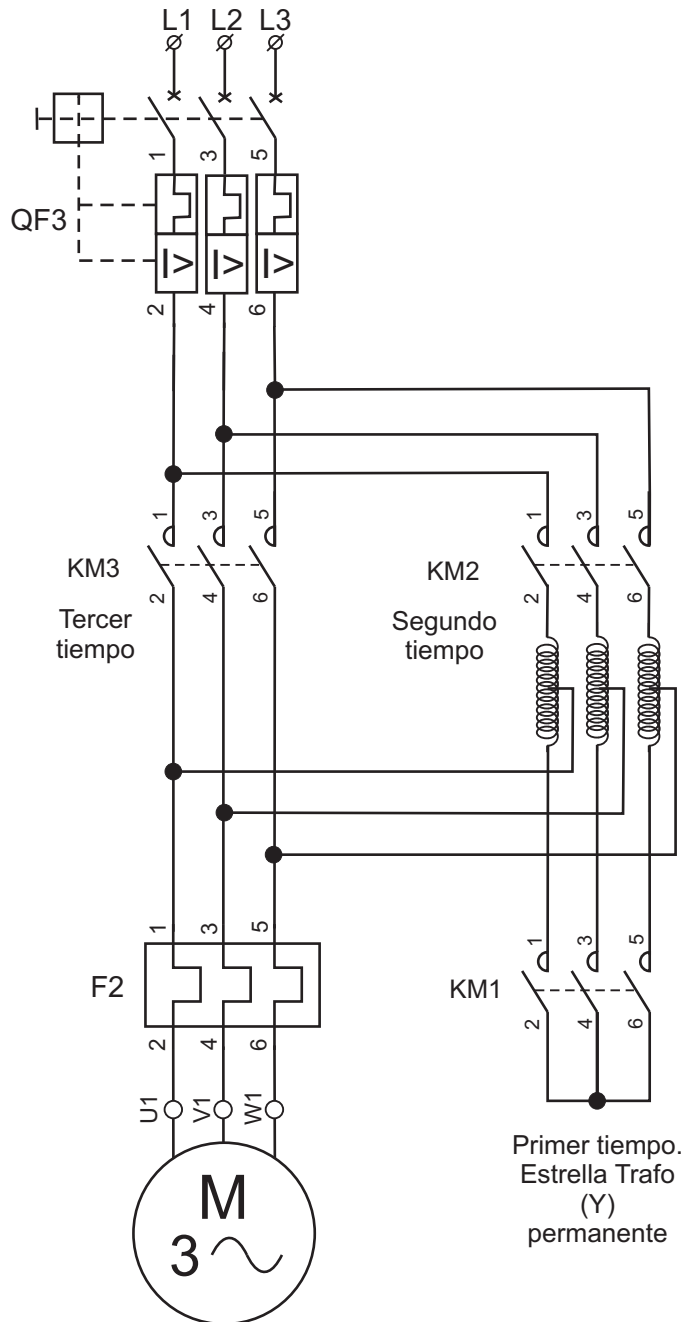
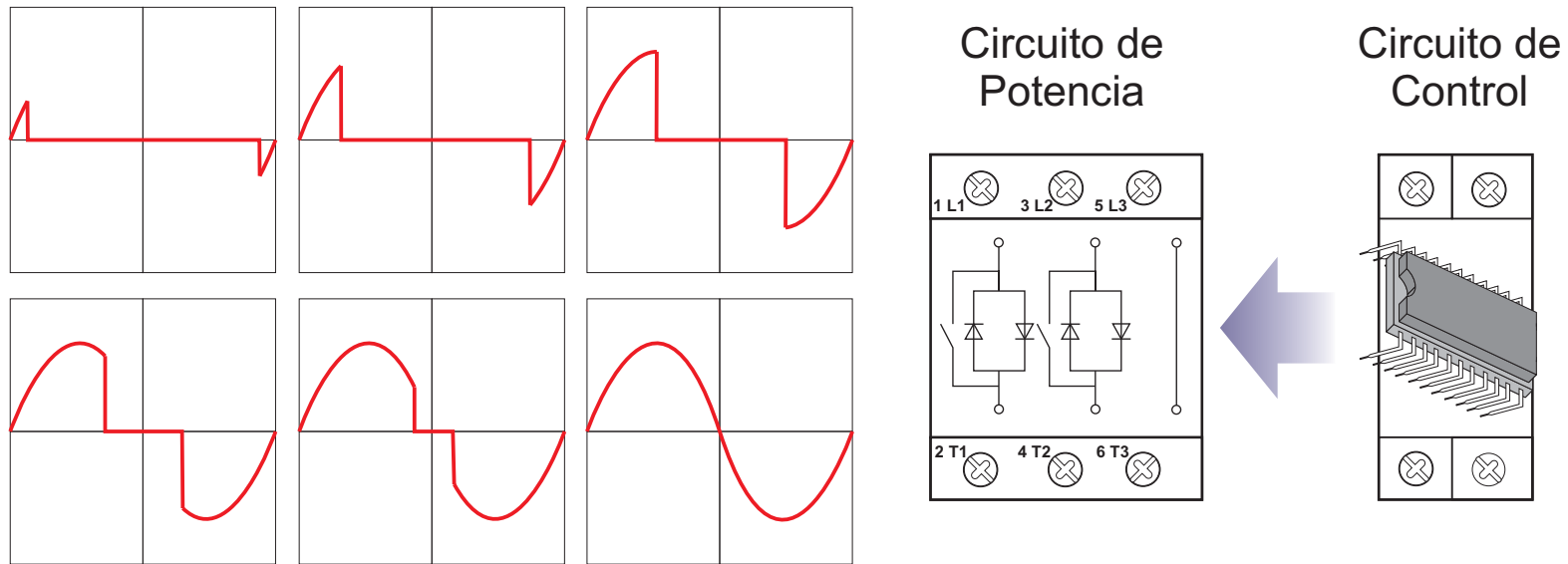

Figura 8.39. Símbolo del arrancador.



Figura 8.40. Curvas del arranque.

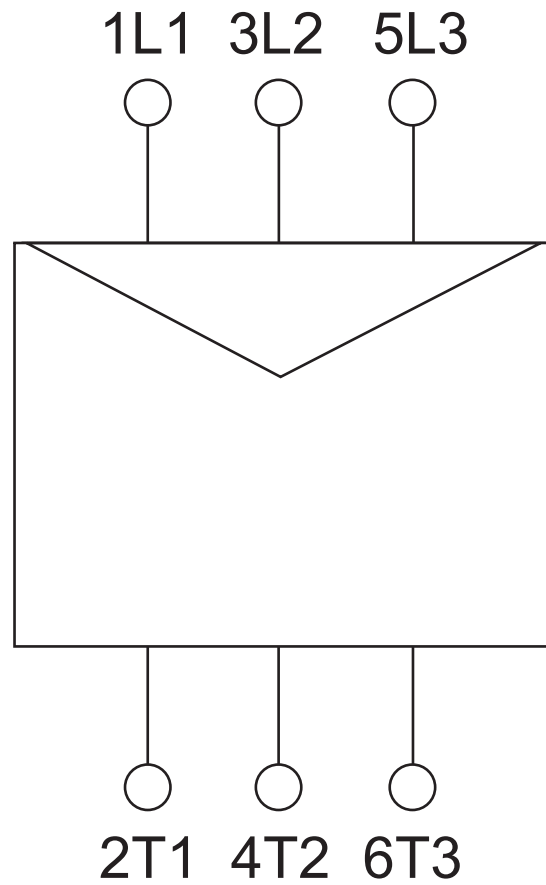

*Figura 8.41 Puesta en marcha de un arrancador de forma directa, con protecciones.*

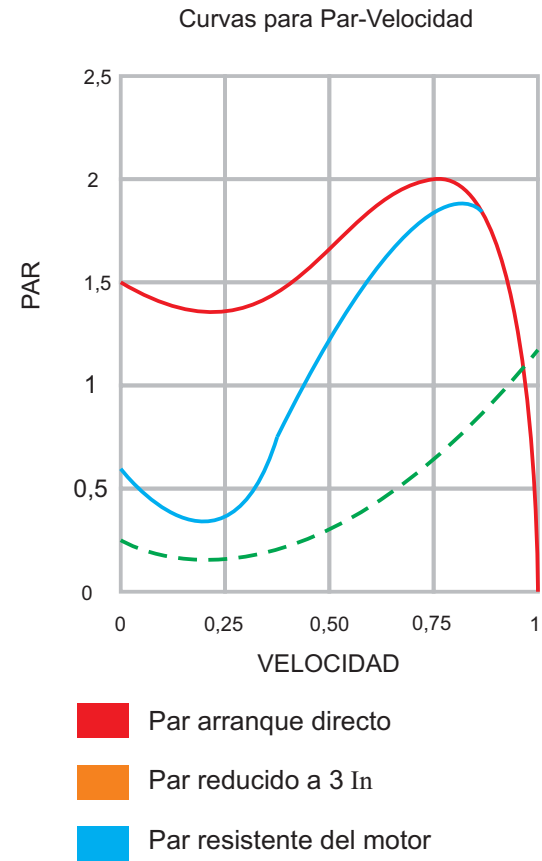
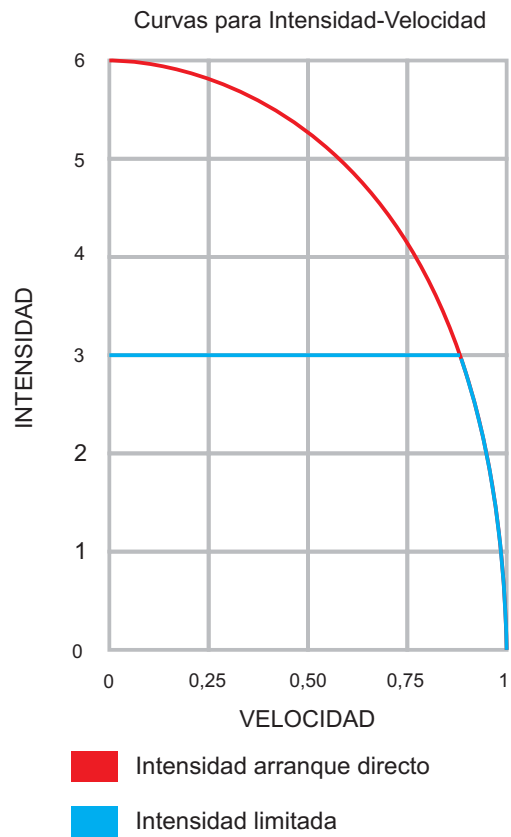
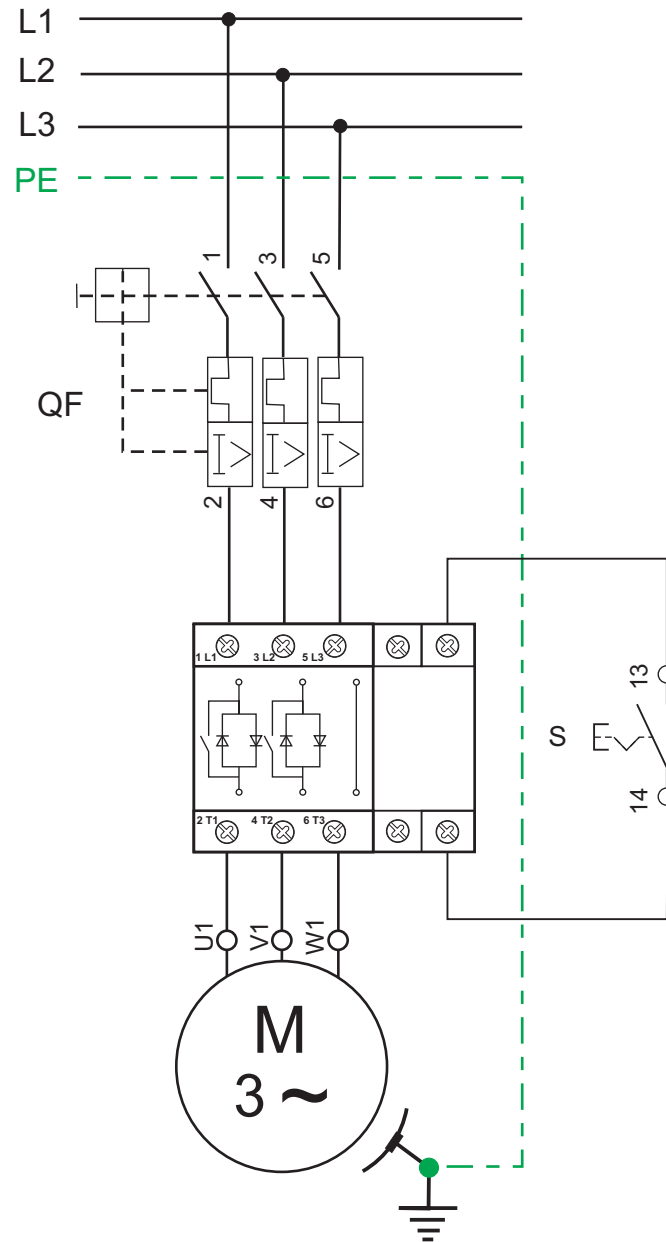
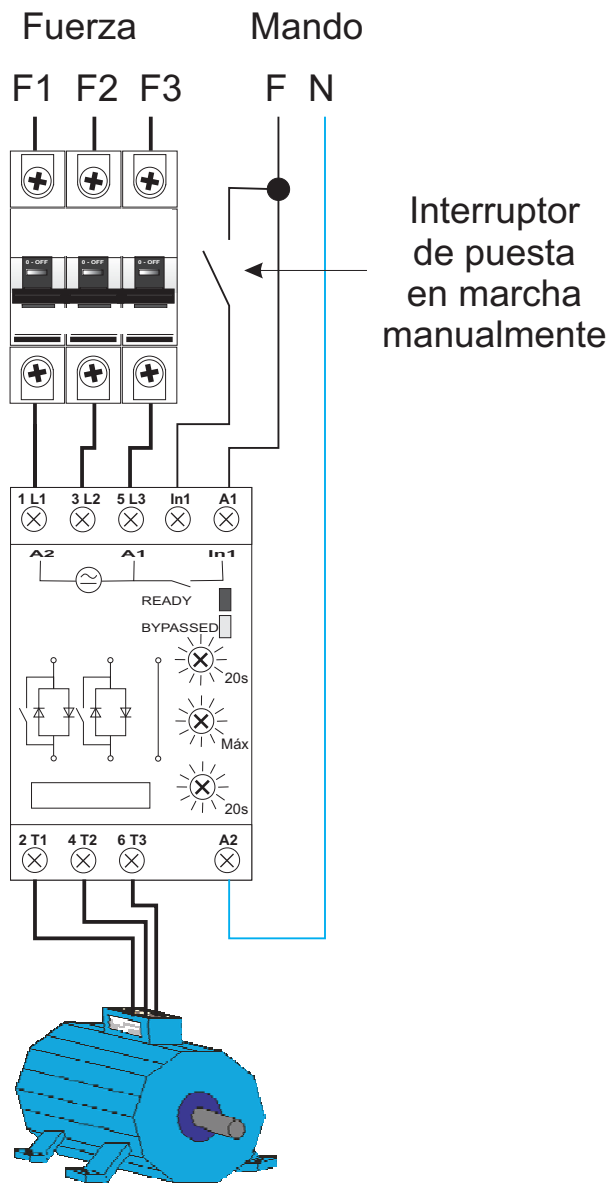

Figura 8.42. Automatismo para la puesta en marcha de un arrancador.



Figura 8.43. La conexión habitual de un motor con dos devanados es en estrella.

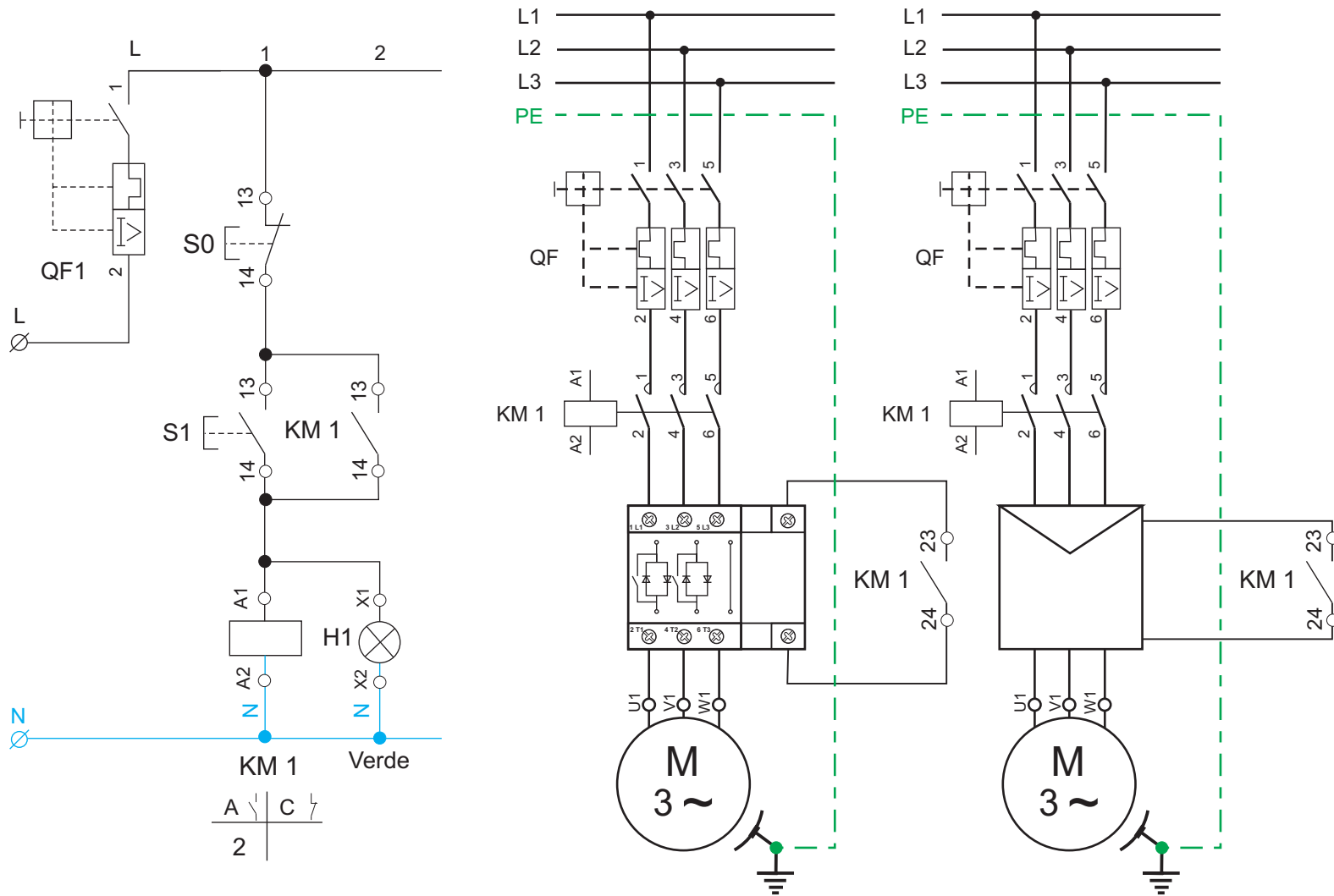

*Figura 8.44. Esquema de potencia para la puesta en marcha de un motor con dos velocidades, con dos devanados en estrella.*



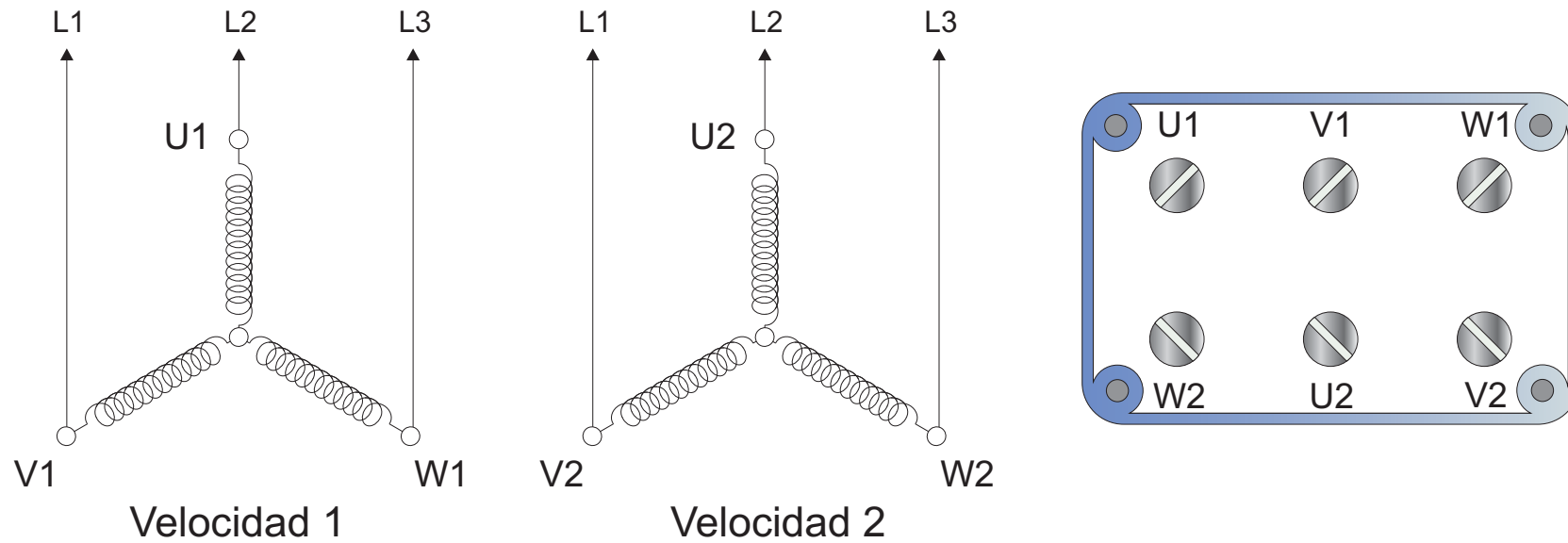
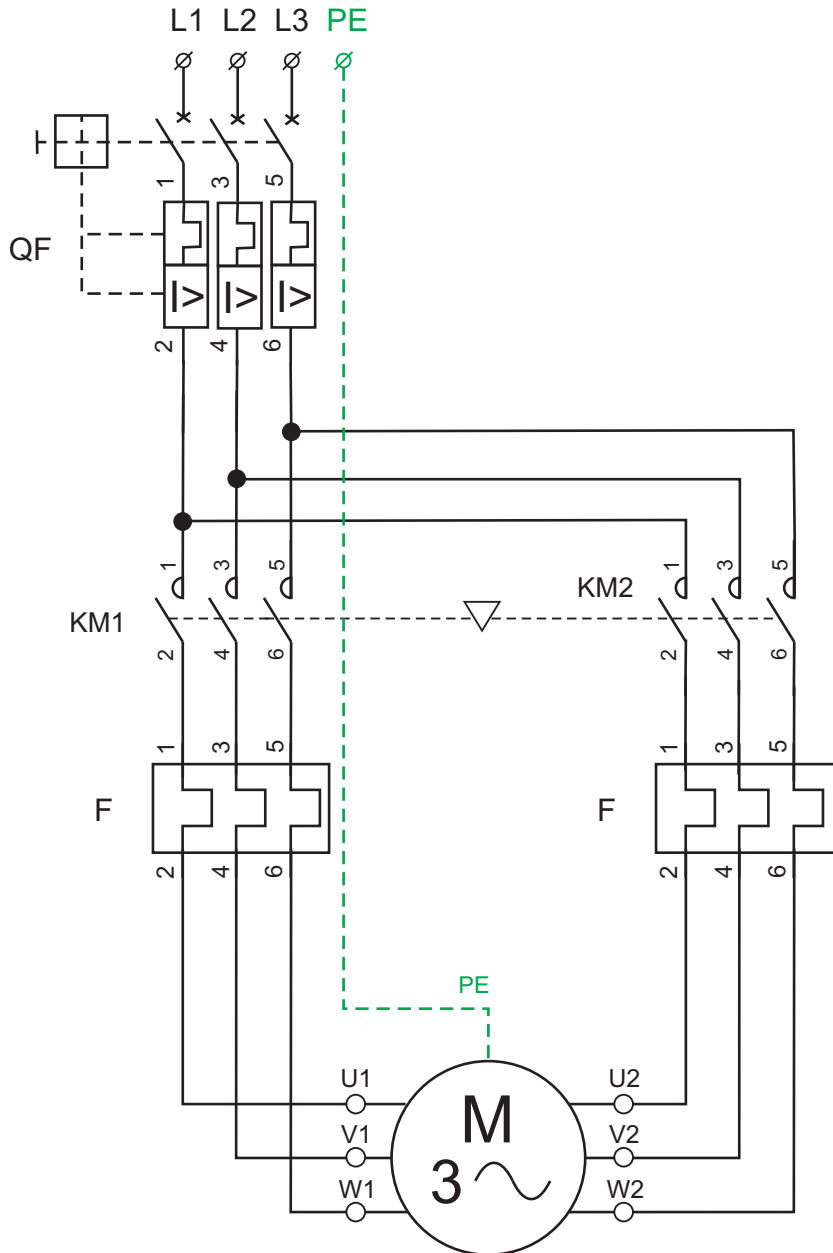

Figura 8.45. Conexión del motor dahlander para velocidad lenta.



Velocidad rápida  
menos polos

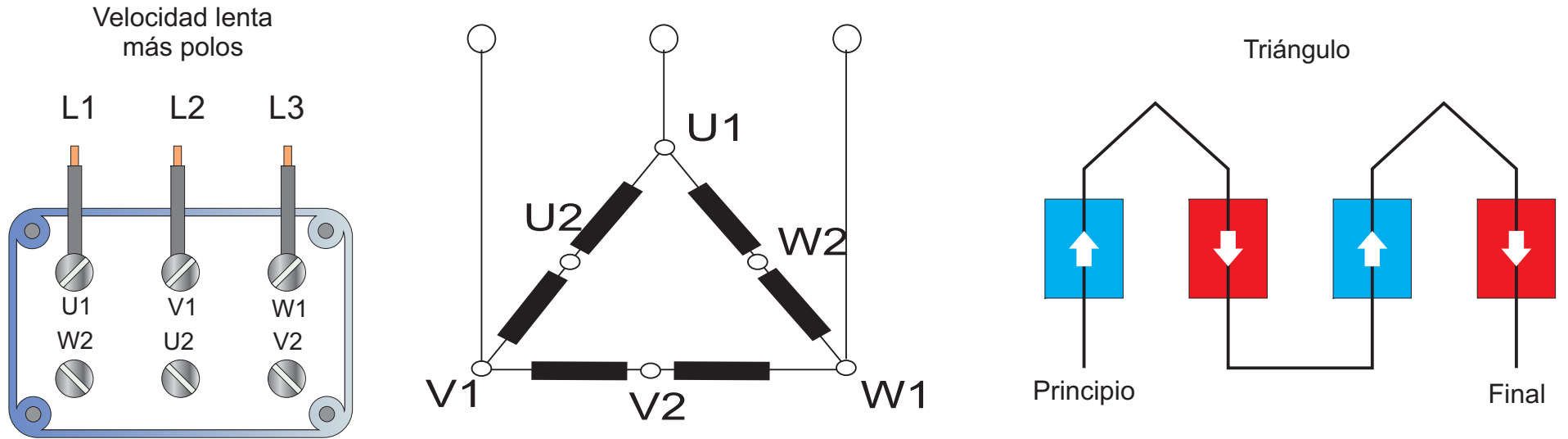
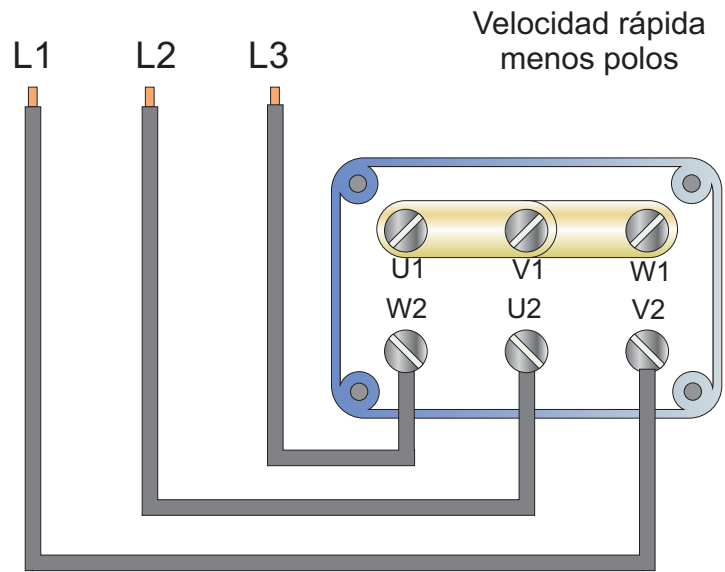

Figura 8.46.  
Conexión del motor dahlander  
para velocidad  
rápida.



*Figura 8.47. Esquema de potencia para la puesta en marcha de un motor dahlander.*



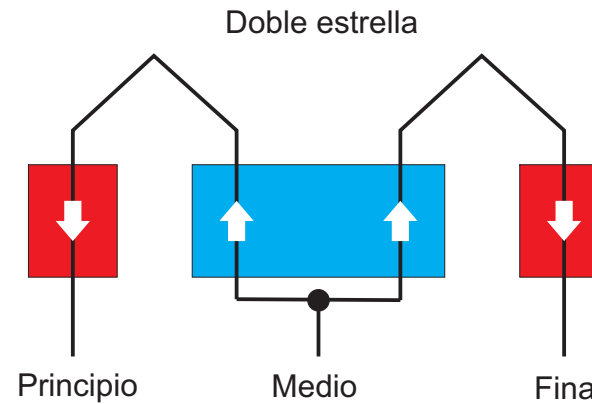
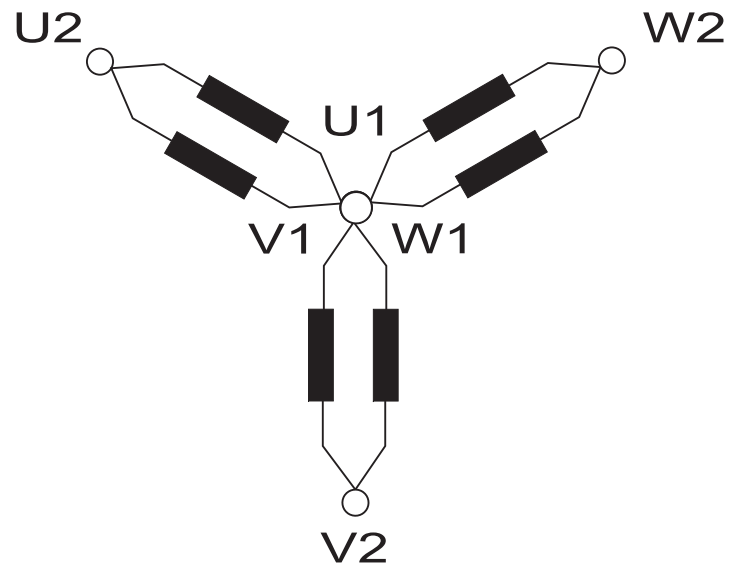
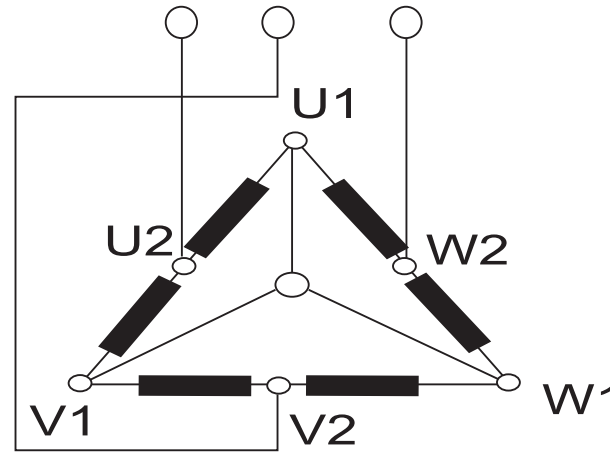
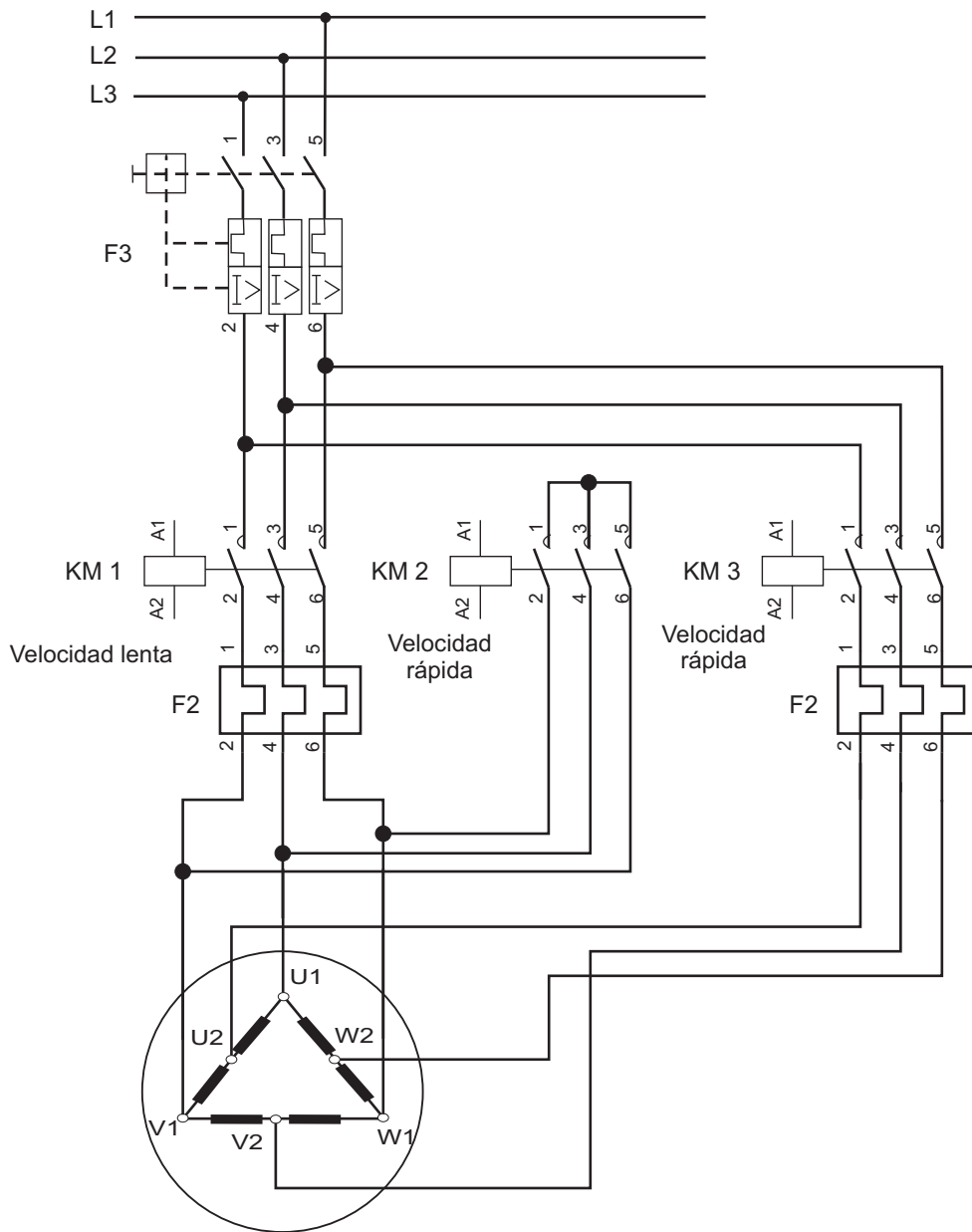
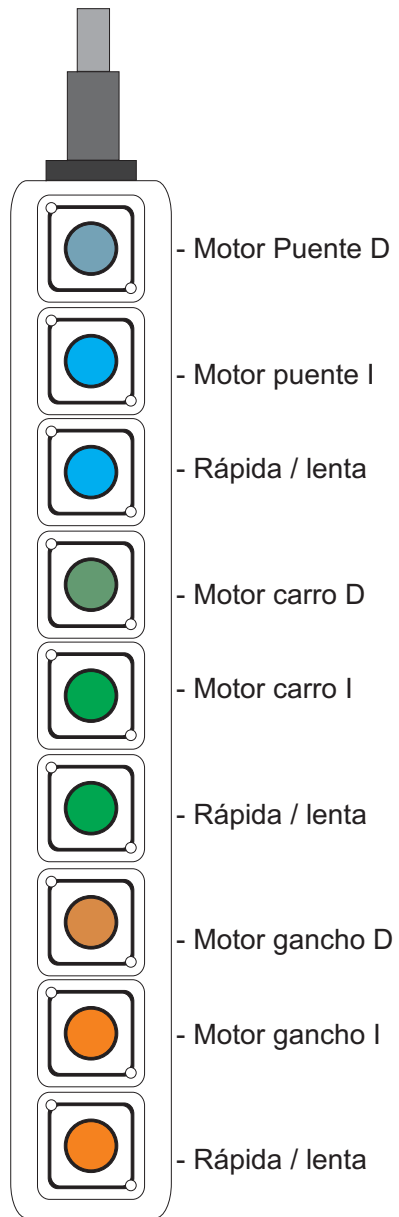

*Figura 8.48. Botonera de control de un puente grúa con doble velocidad (dahlander).*



Figura 8.49. Esquema de mando para la puesta en marcha de un motor dahlander



Figura 8.50. Esquema de bloques del variador de frecuencia.

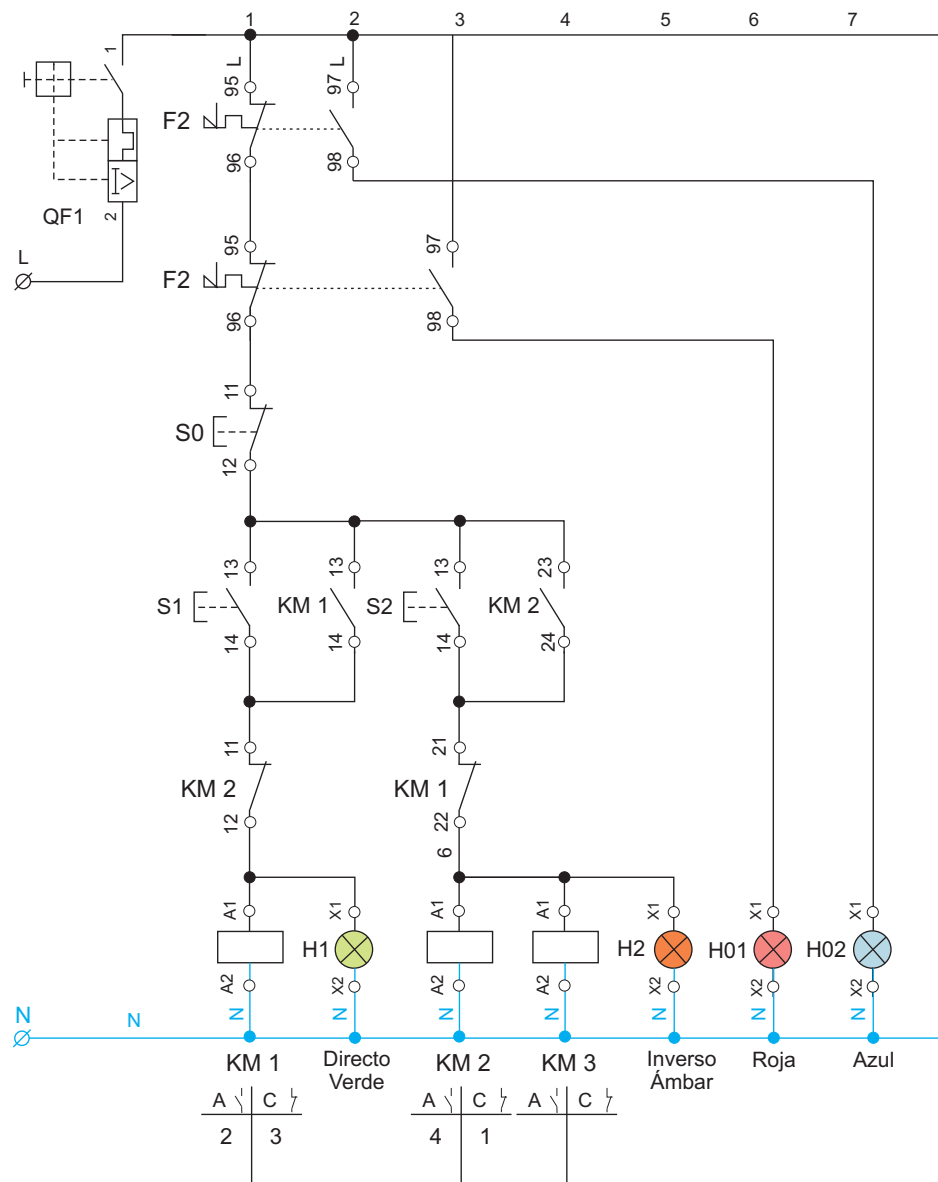

*Figura 8.51. Variador de frecuencia.*

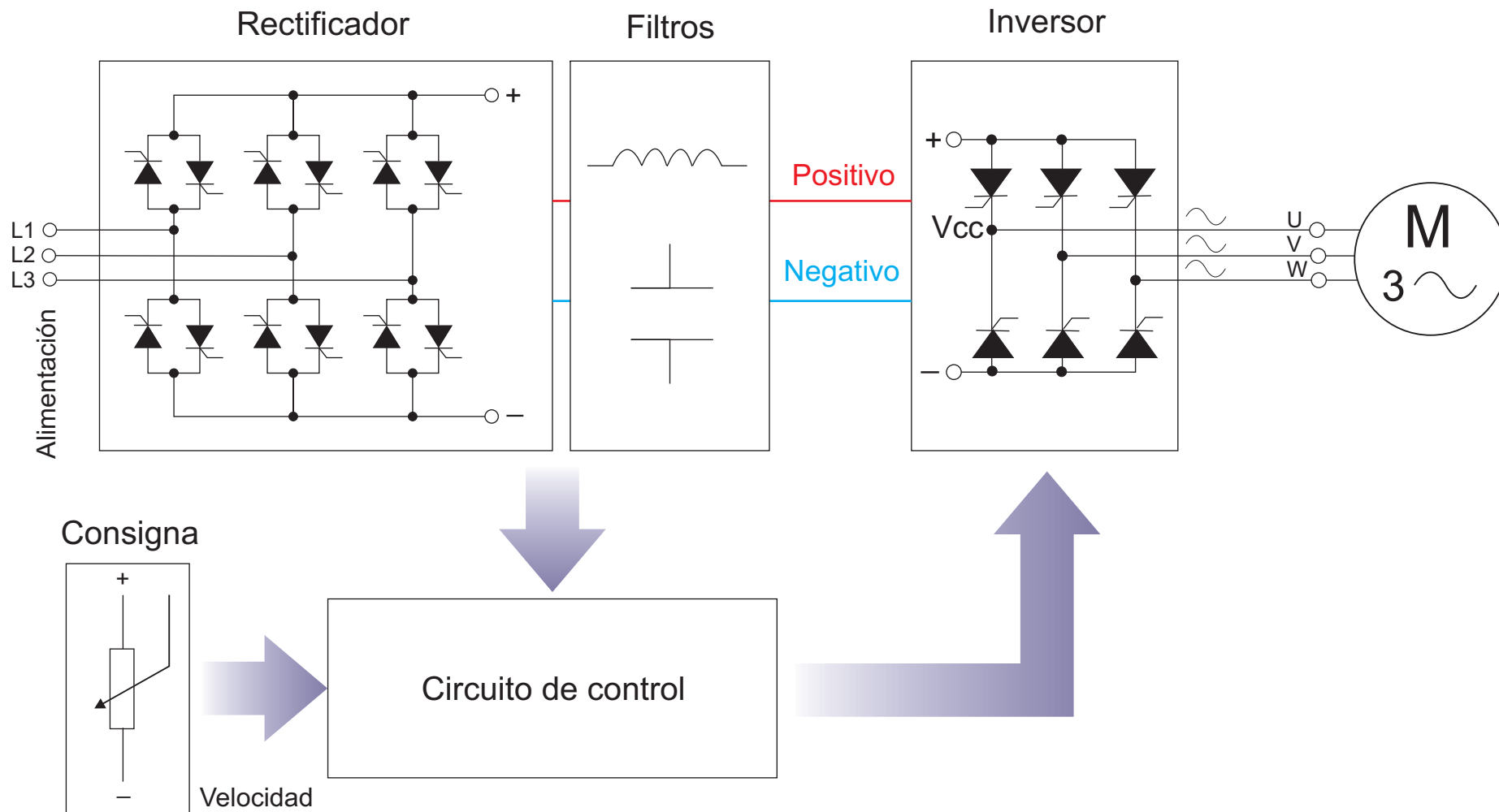
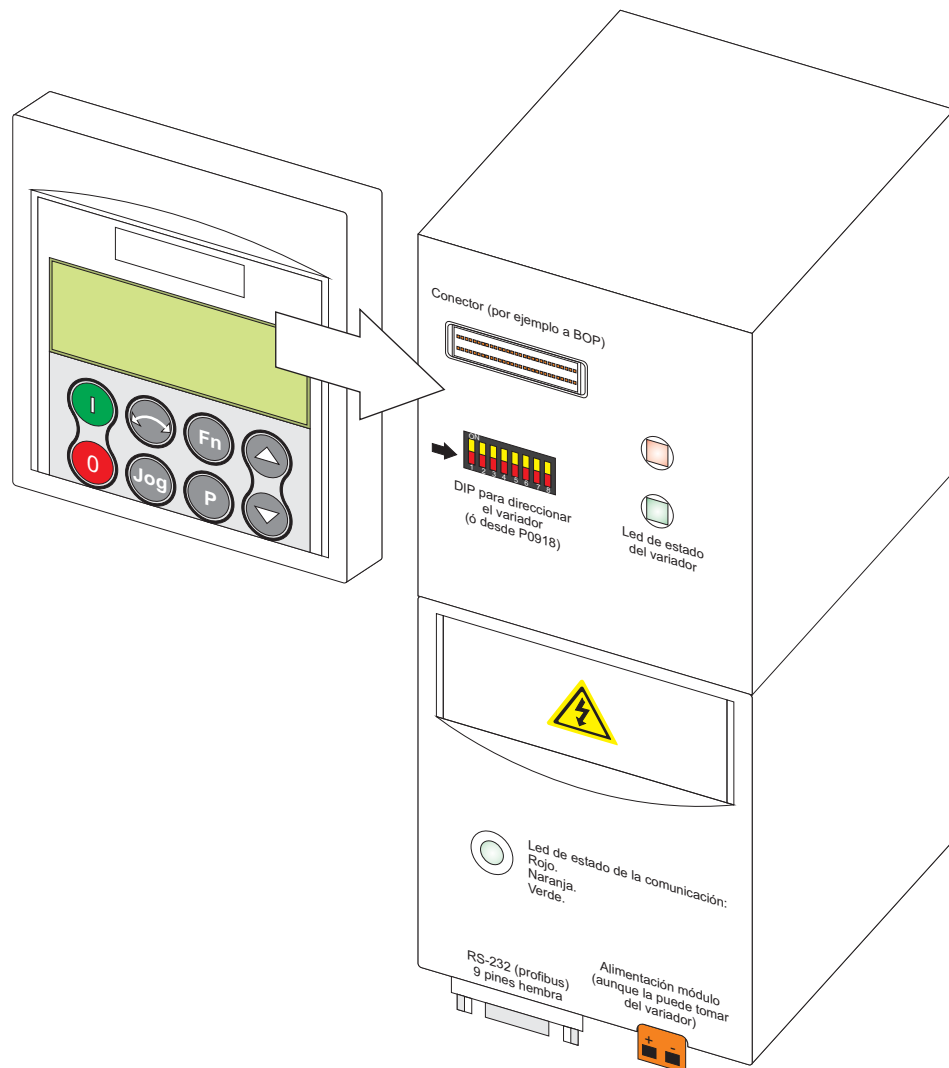

Figura 8.52. La frecuencia de salida se constituye a base de impulsos.





Figura 8.53. La rapidez de los transistores permite construir las tres fases a base de impulsos.

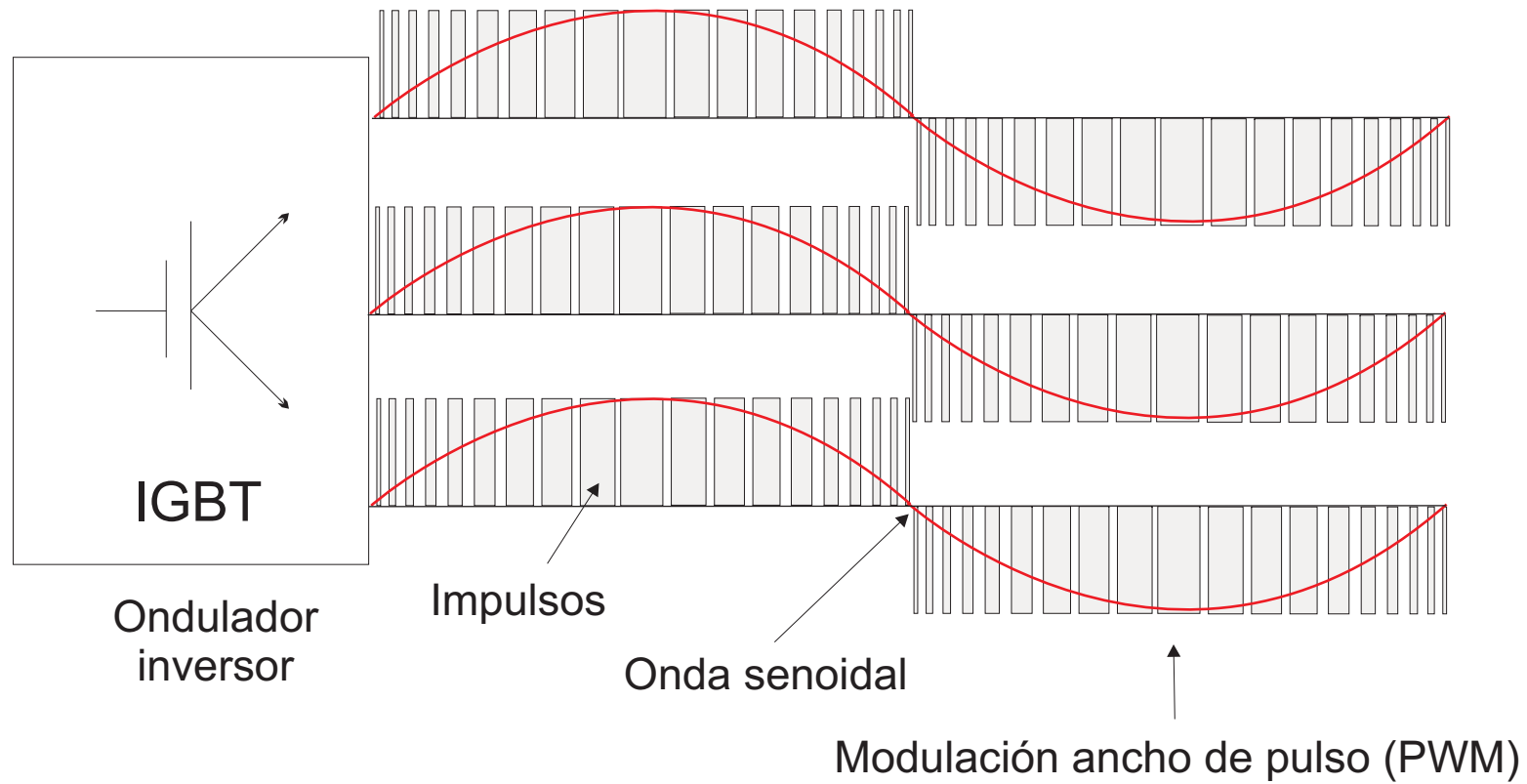

Figura 8.54. Valor de la tensión  $U$ , en un momento determinado.

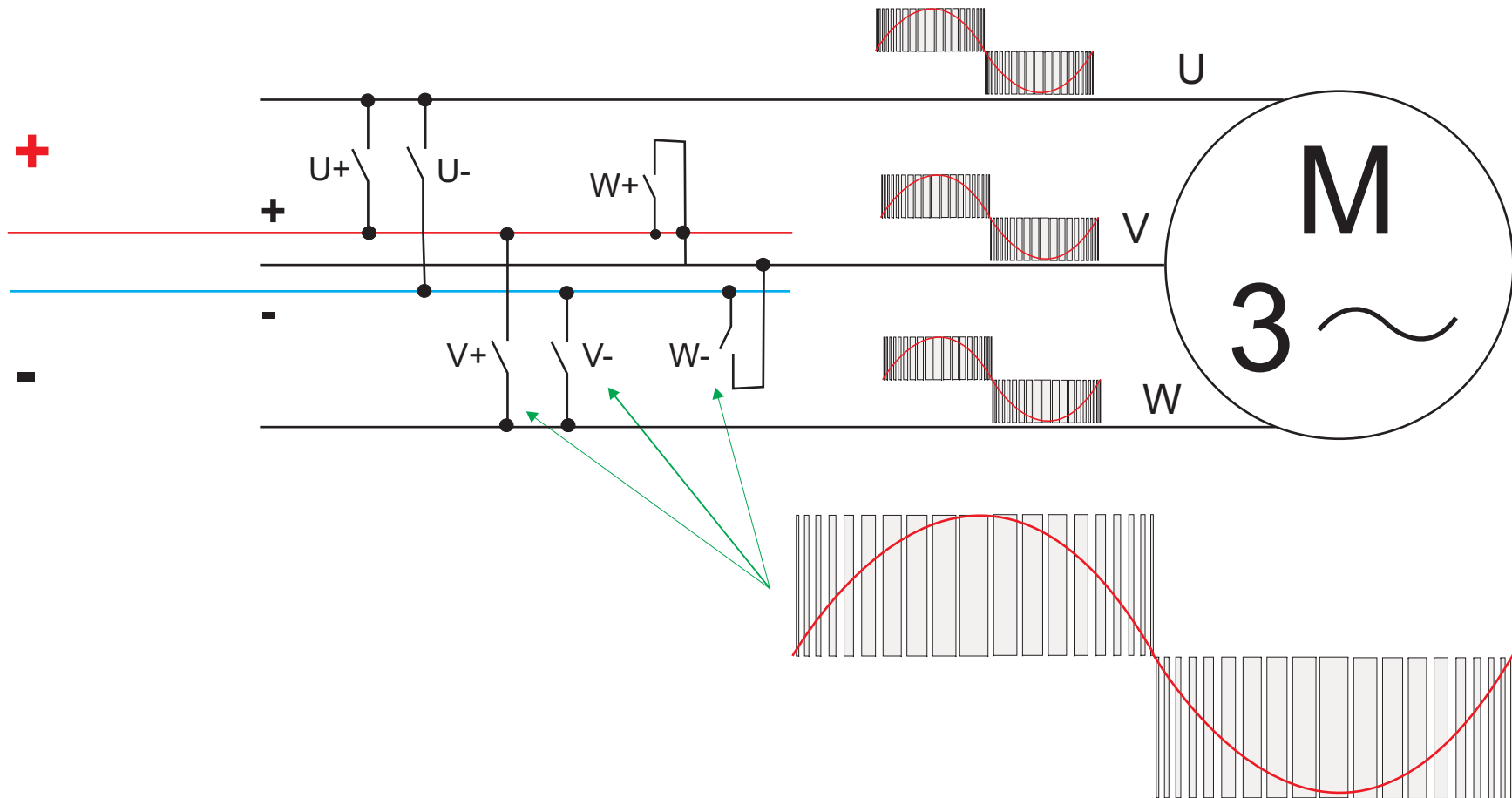

Figura 8.55. Aspecto del frontal de dos variadores de frecuencia.

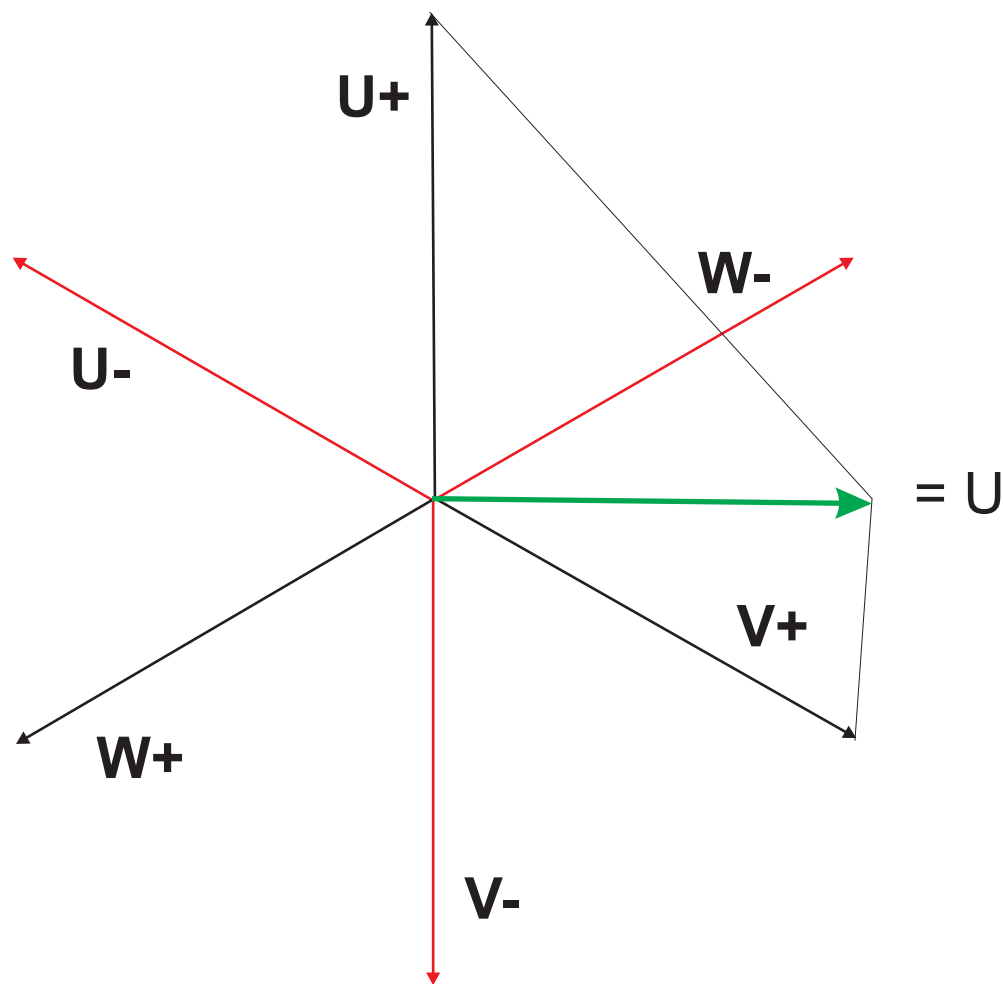

Figura 8.56. Ejemplo de programación de las rampas de aceleración y deceleración.

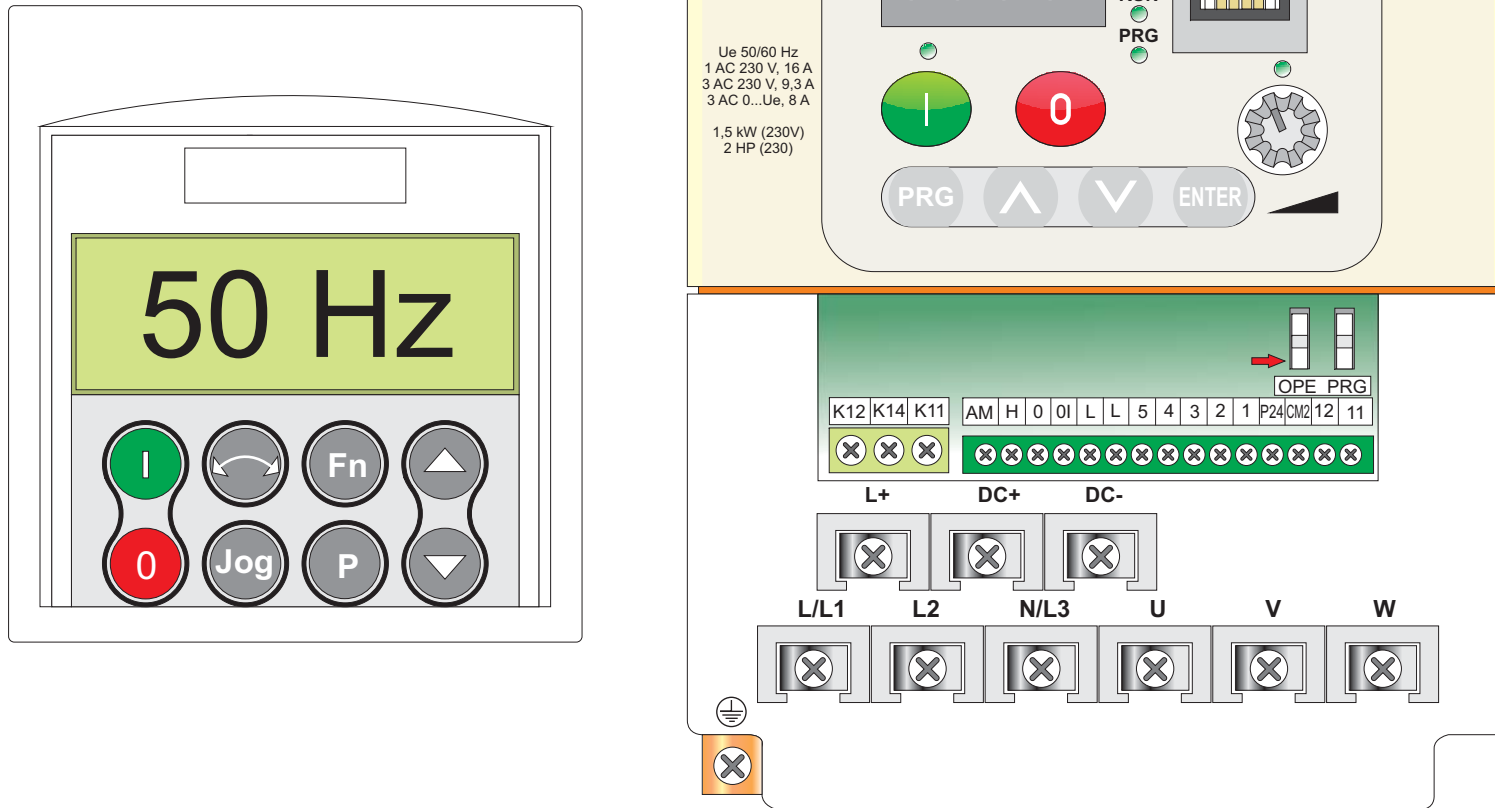

*Figura 8.57. Identificación de un variador de frecuencia.  
Control y potencia respectivamente.*

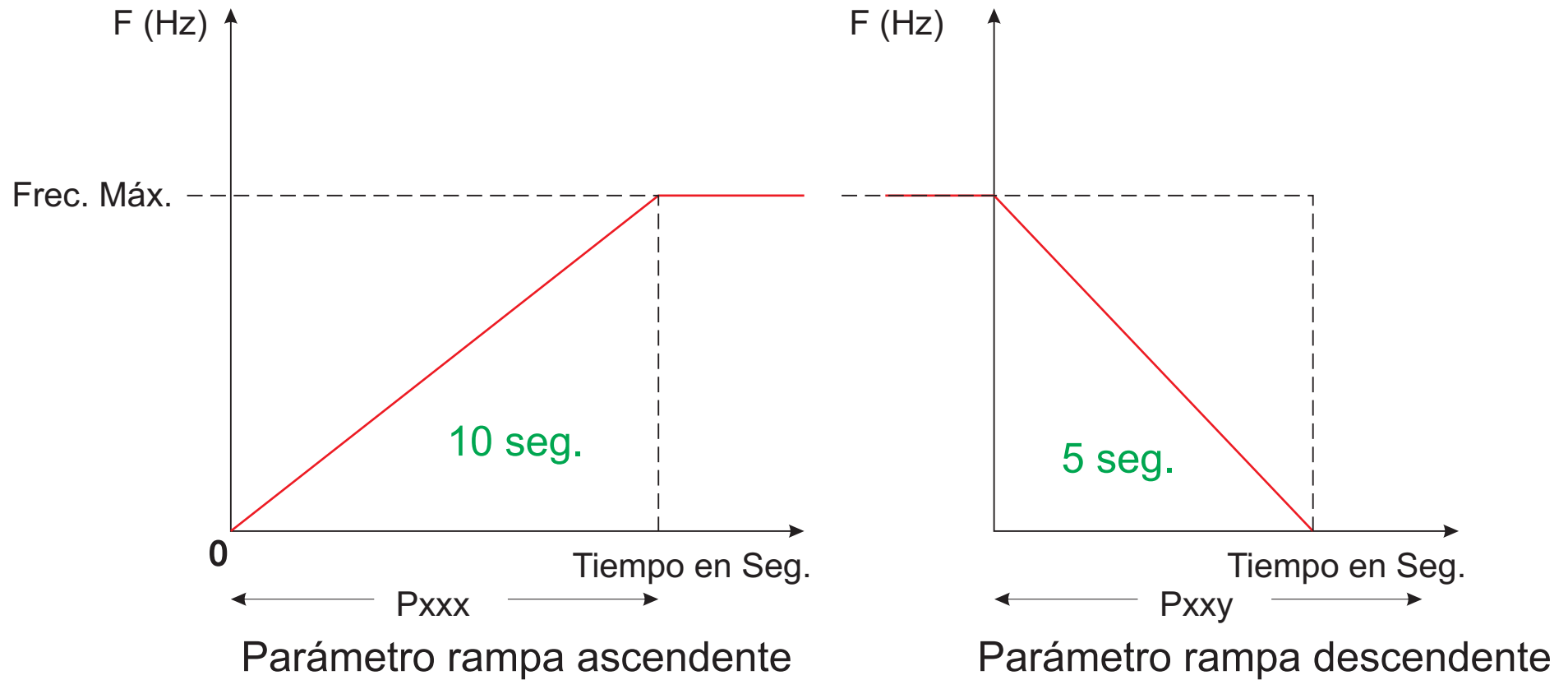
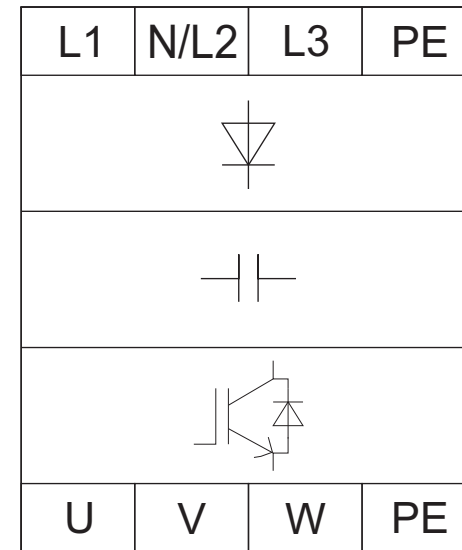
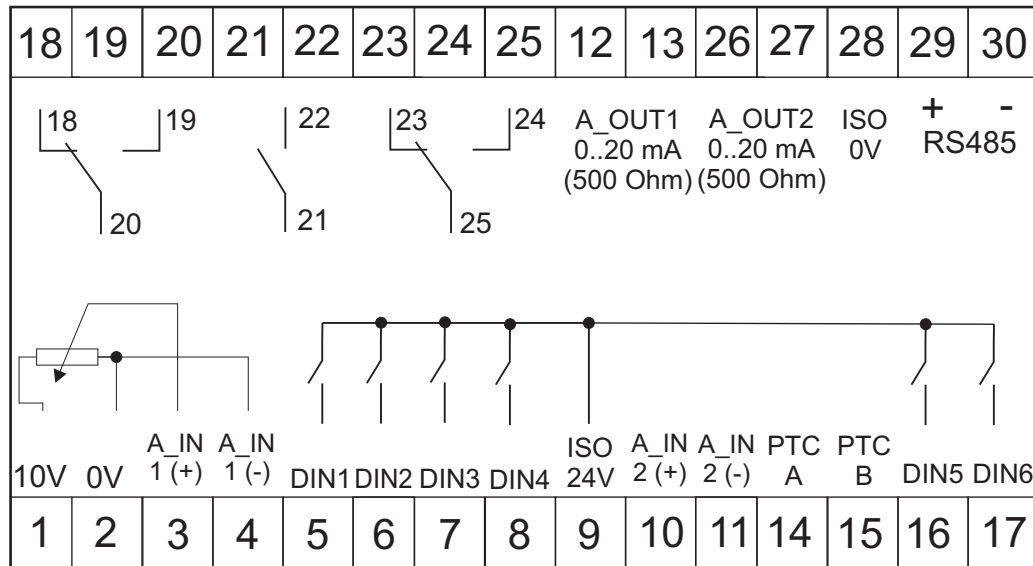

Salidas digitales

- Frecuencia alcanzada.
- Error de velocidad.
- Motor parado, etc.

Salidas analógicas

- Válvulas.
- Medidores.
- Displays, etc.

Comunicaciones industriales

- Profibus.
- EtherCat.
- Modbus, etc.

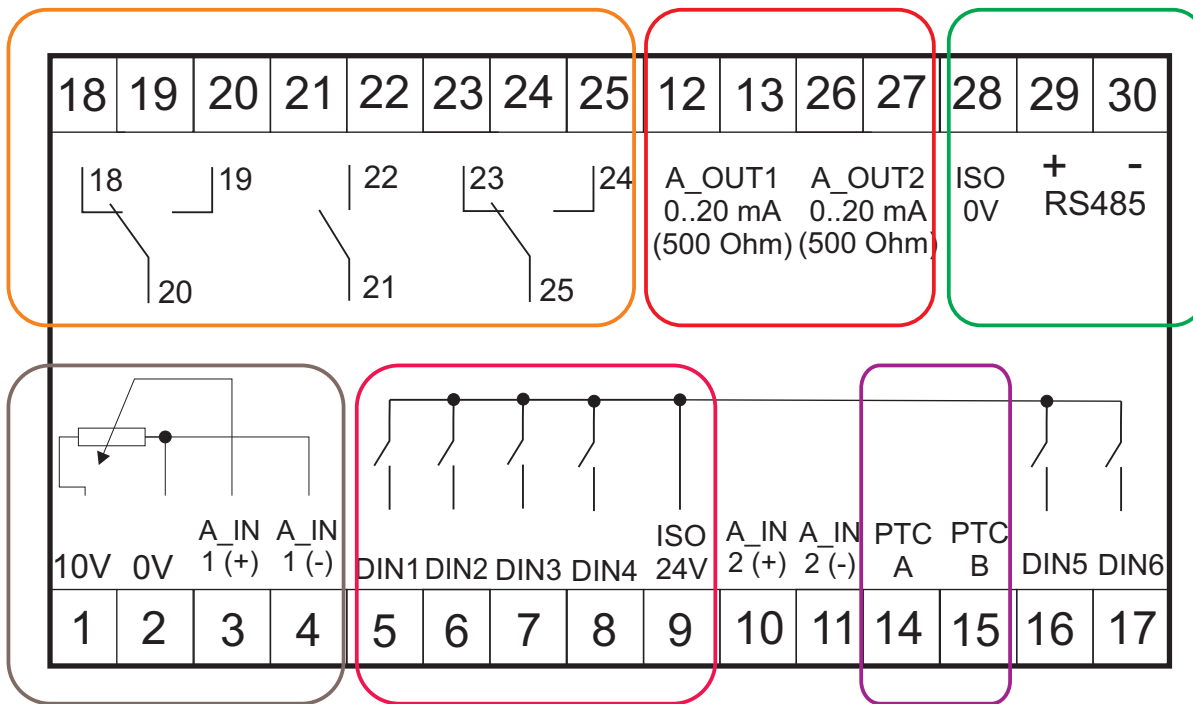

Entradas analógicas

- Potenciómetros.
- Presostatos.
- Vacuostatos.
- Termostatos, etc.

Entradas digitales

- Marcha.
- Parada.
- Inversión.
- Acuse de fallo, etc.

Entradas PTC

- Sensores específicos de temperatura.

Figura 8.58. Esquema de conexiones de la parte de control de un variador.





Figura 8.59. Esquema de conexiones de la parte de potencia de un variador.



Figura 8.60. Esquema representativo del ejemplo propuesto.



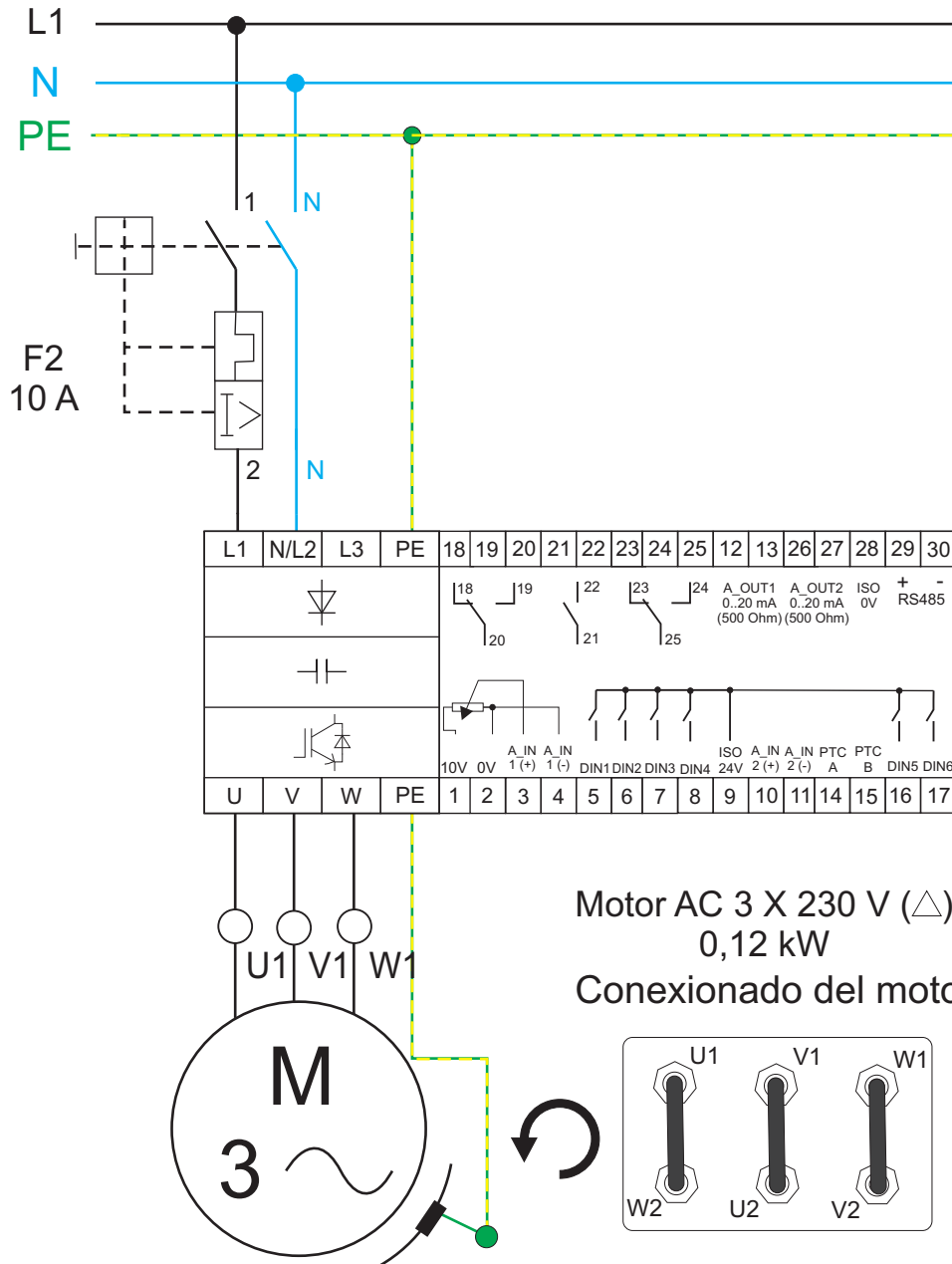

Figura 8.61. Bobinado rotórico. Detalle de los anillos y conexión interna del mismo.

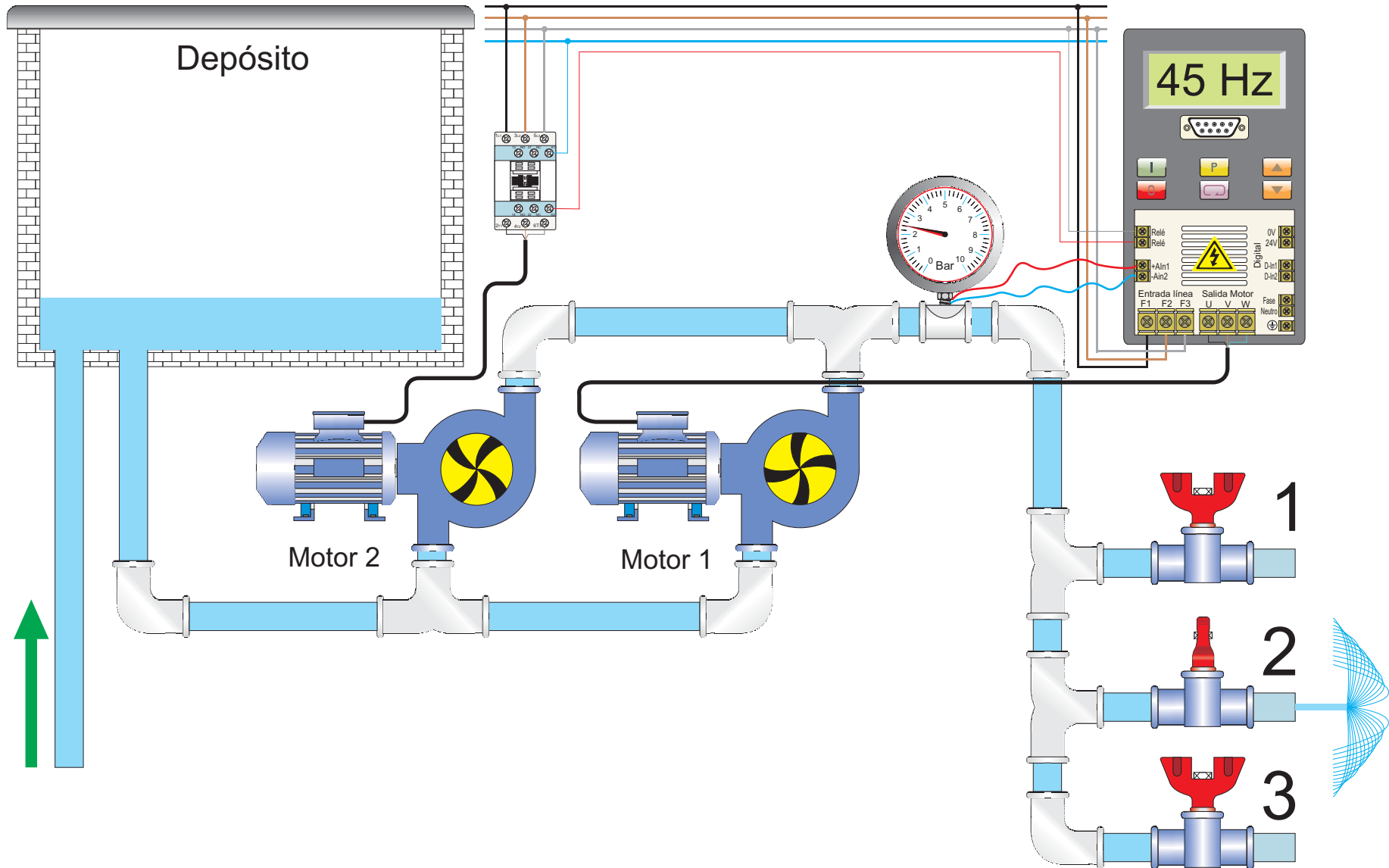

Figura 8.62. Símbolo motor rotor bobinado, caja de bornes Y esquema de un arranque en tres tiempos.

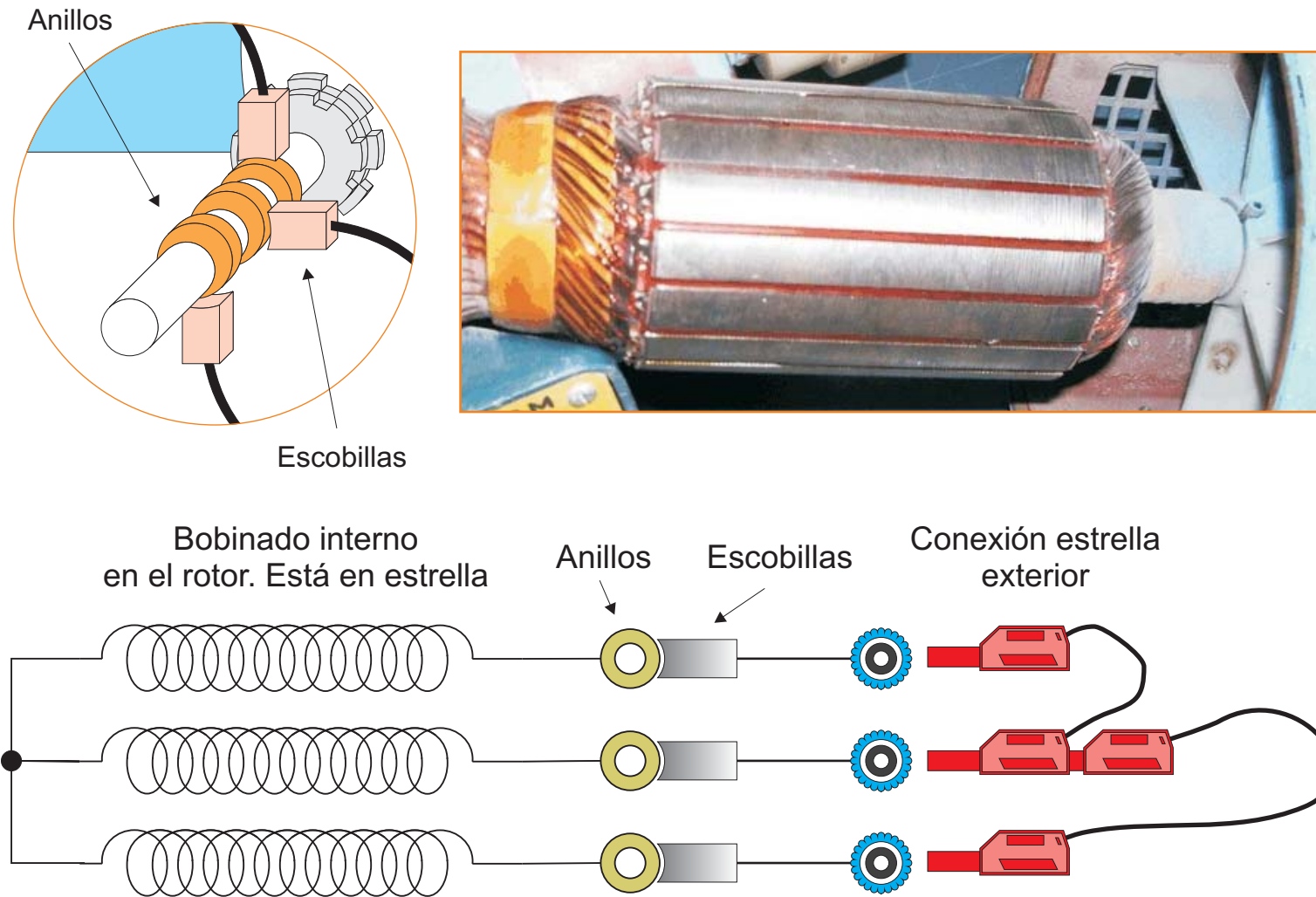

- Intensidad arranque directo
- Intensidad 2º tiempo
- Intensidad 1º tiempo
- Arranque

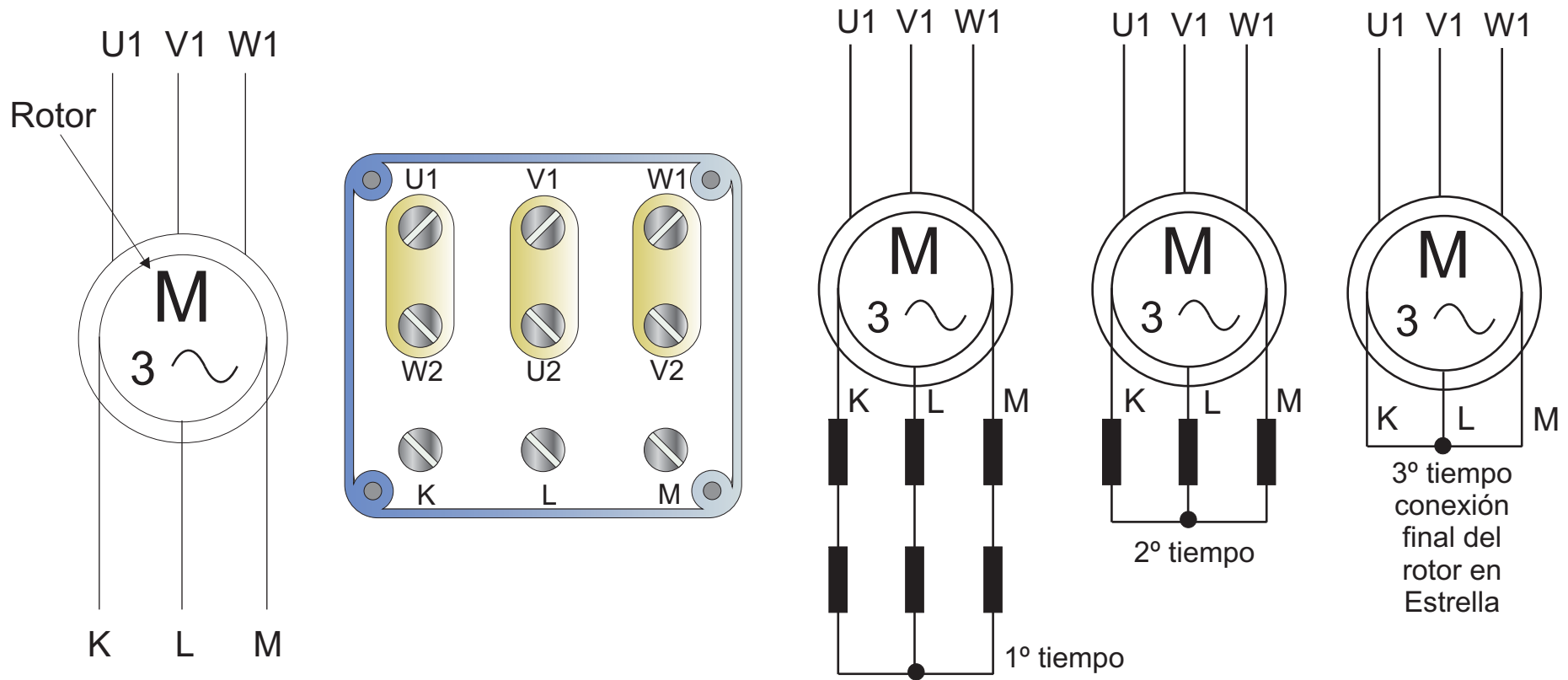
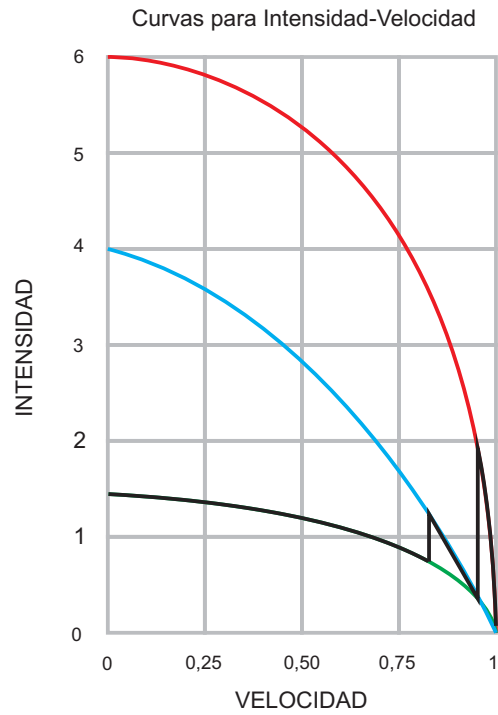
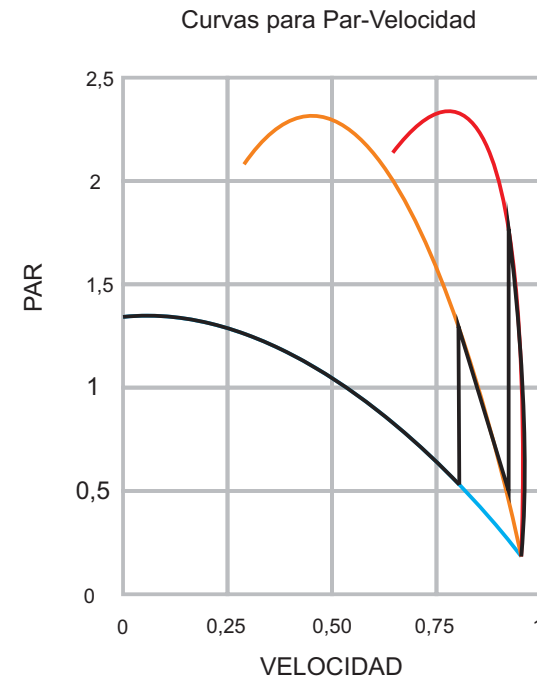

- Par sin resistencia
- Par 2º tiempo
- Par 1º tiempo
- Arranque

Figura 8.63. Curvas del arranque.

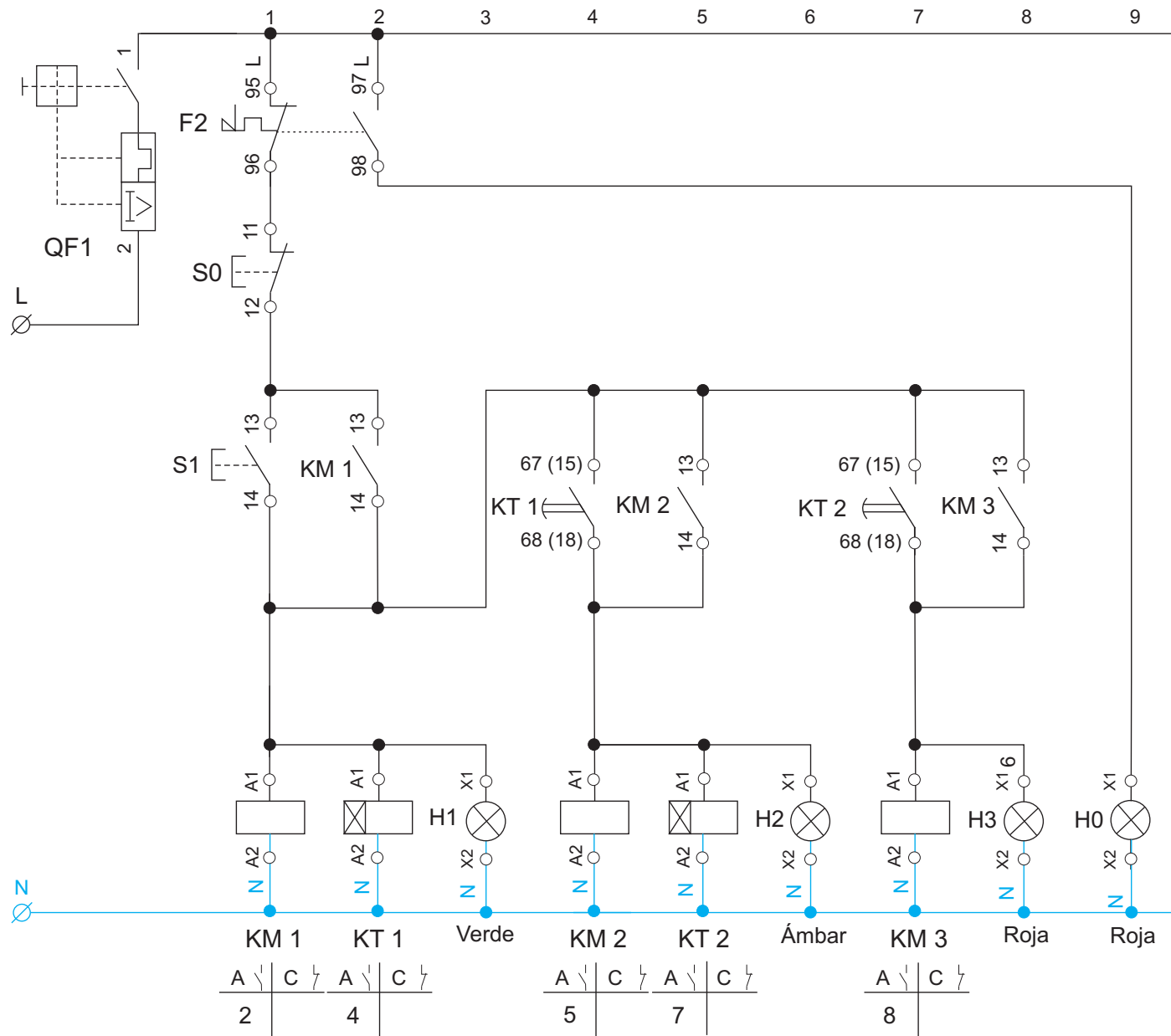

Figuras 8.64 Esquema de mando.

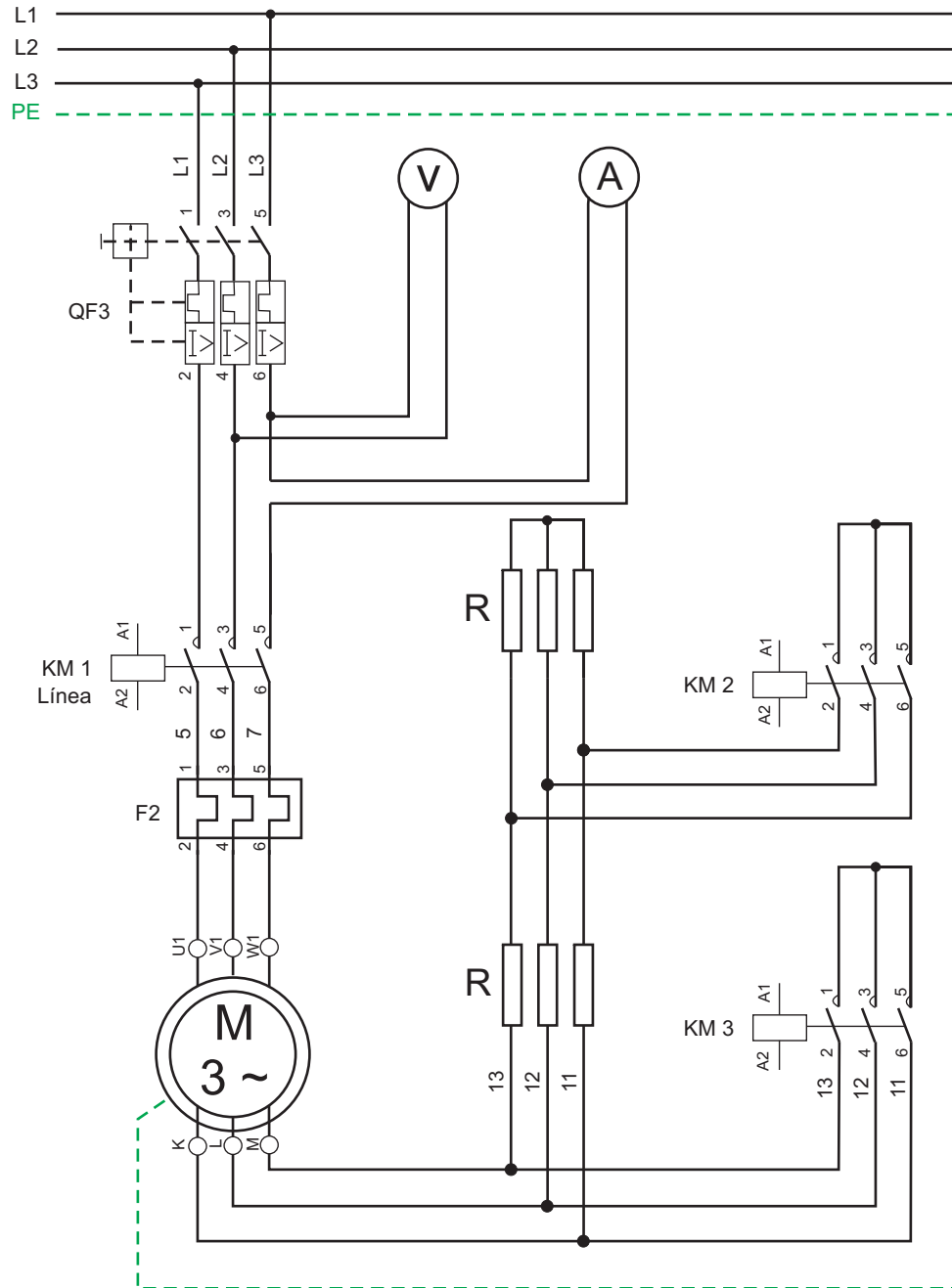

Figuras 8.65 Esquema de potencia.





Figura 8.66. Creación de dos flujos desplazados  $90^\circ$  entre sí.



Figura 8.67. Arranque del motor sin y con condensador.

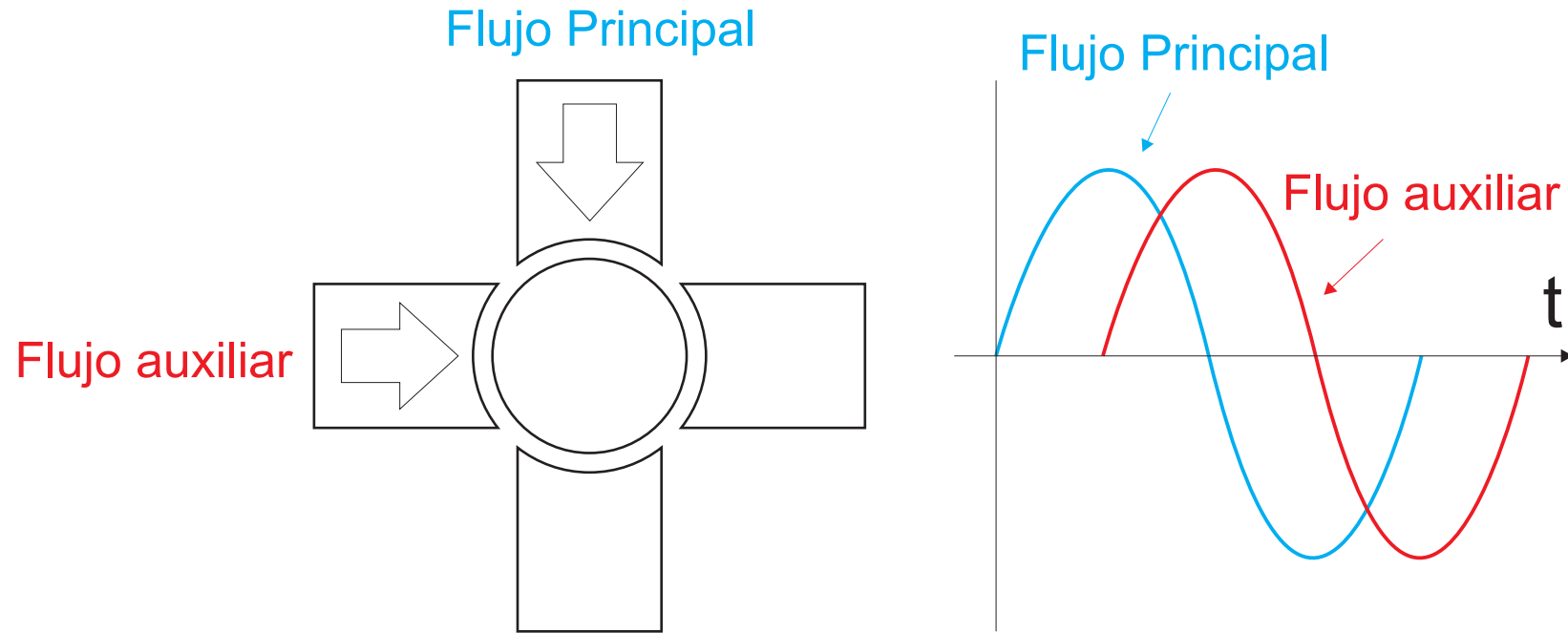

*Figura 8.68. Símbolos del motor monofásico y el motor universal respectivamente.*

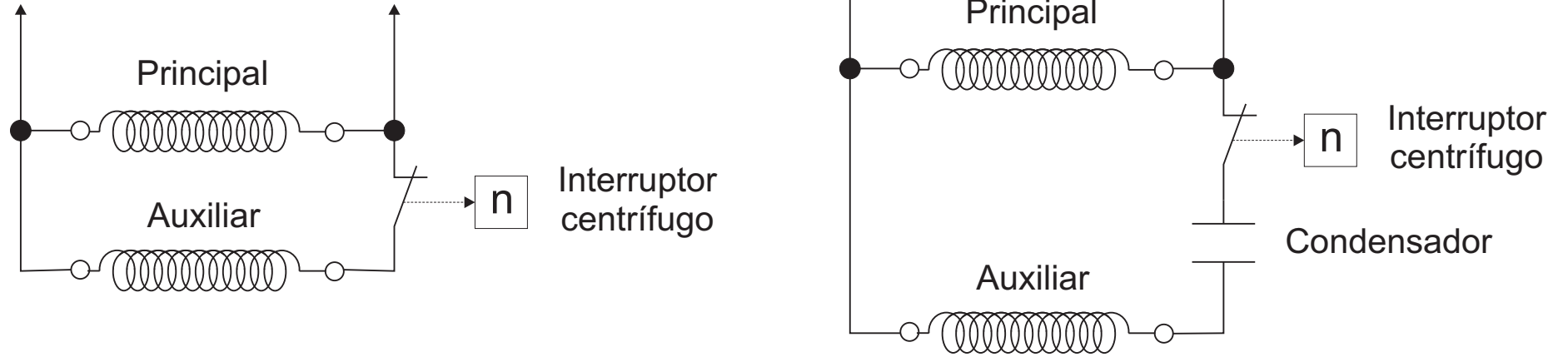
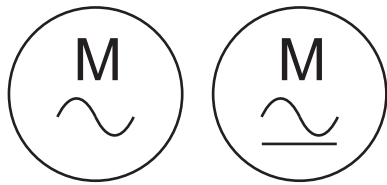
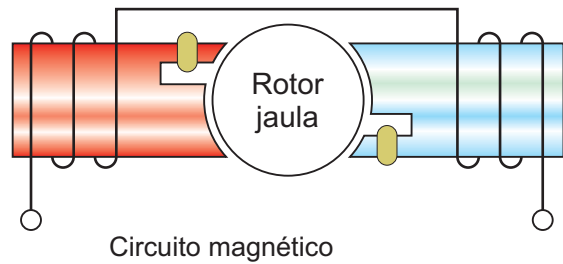

*Figura 8.69. Motor con espira en cortocircuito.*

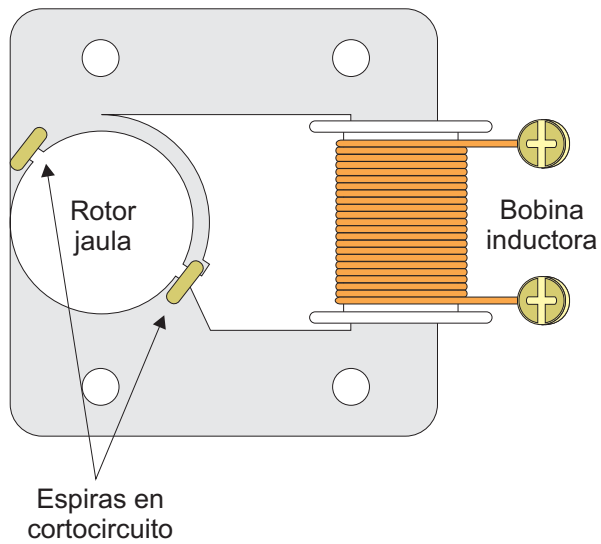



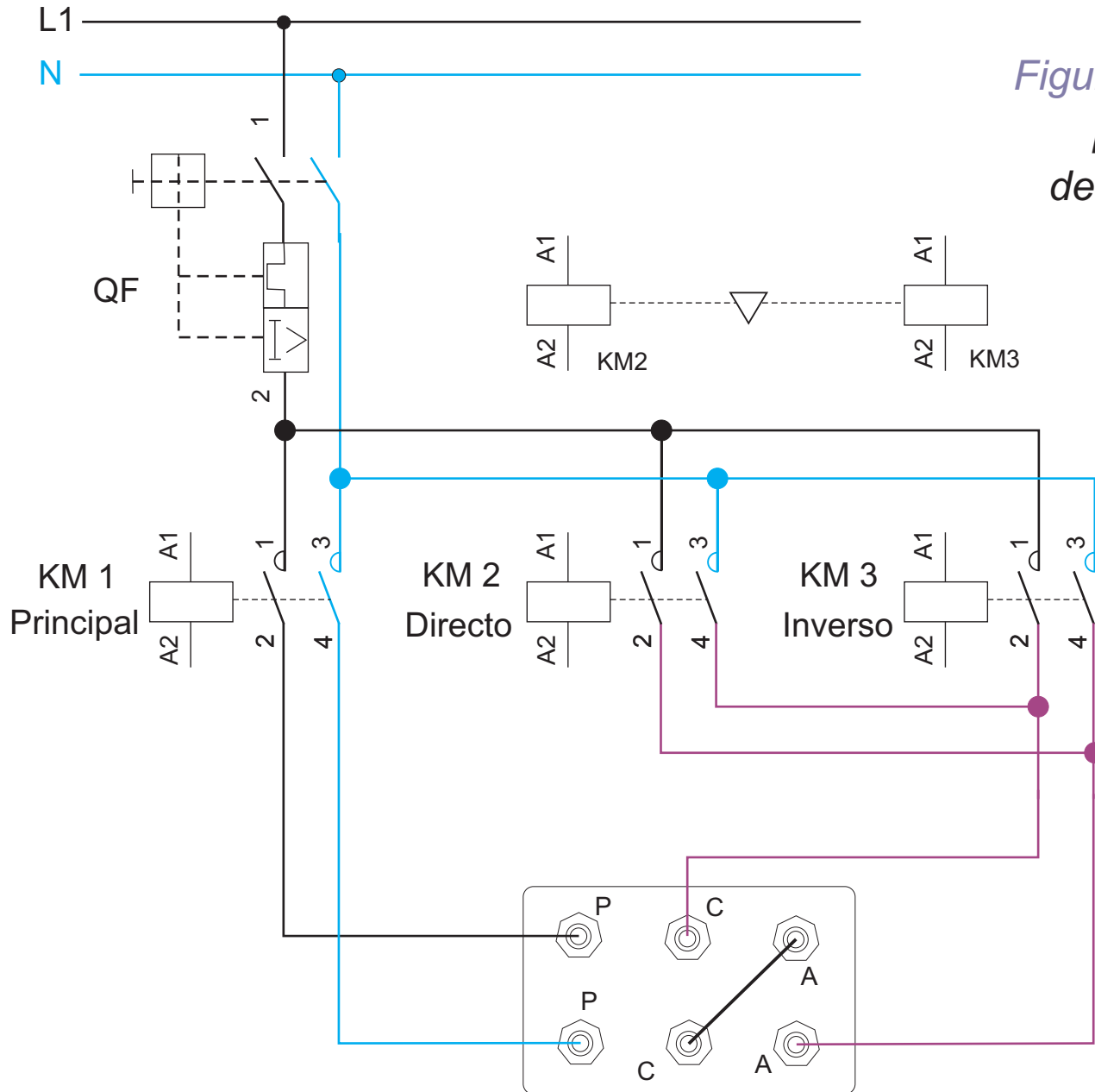

*Figuras 8.70. Esquema de potencia para la inversión de sentido de giro de un motor monofásico.*

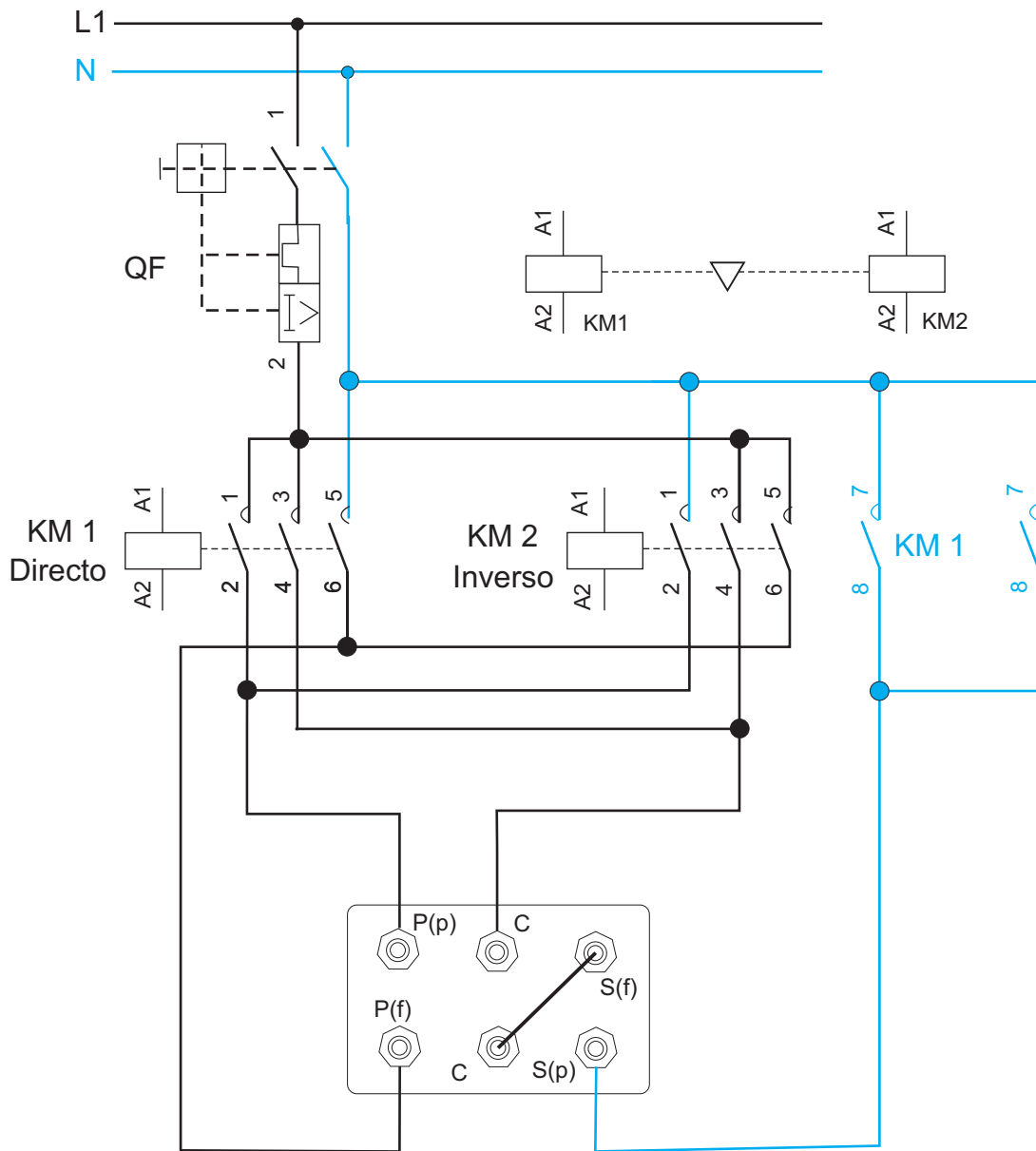

*Figuras 8.71. Esquema de potencia para la inversión de sentido de giro de un motor monofásico.*



Figura 8.72. Alternador con bobinado inductor en el rotor.



Figura 8.73. Acoplamiento motor-generator.



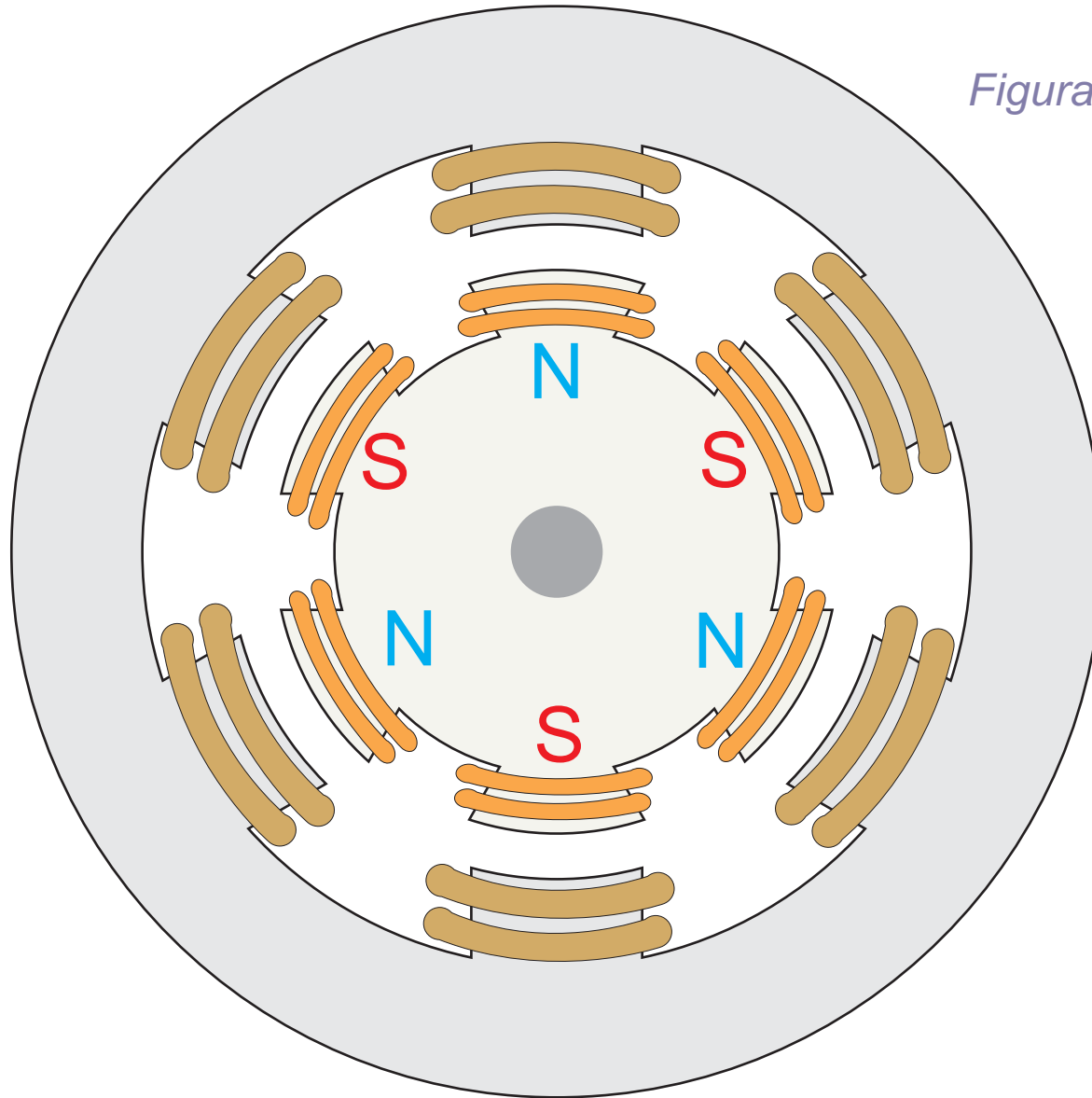

Figura 8.74. Alternador autoexcitado.

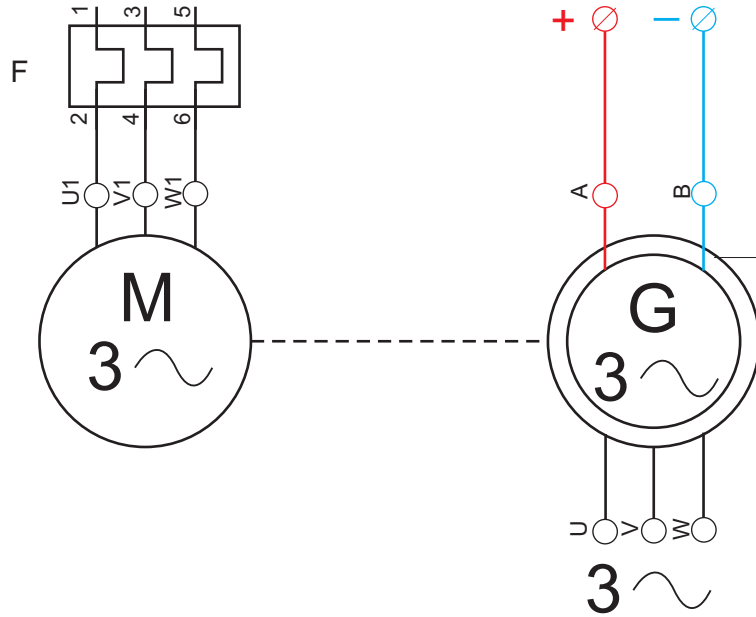
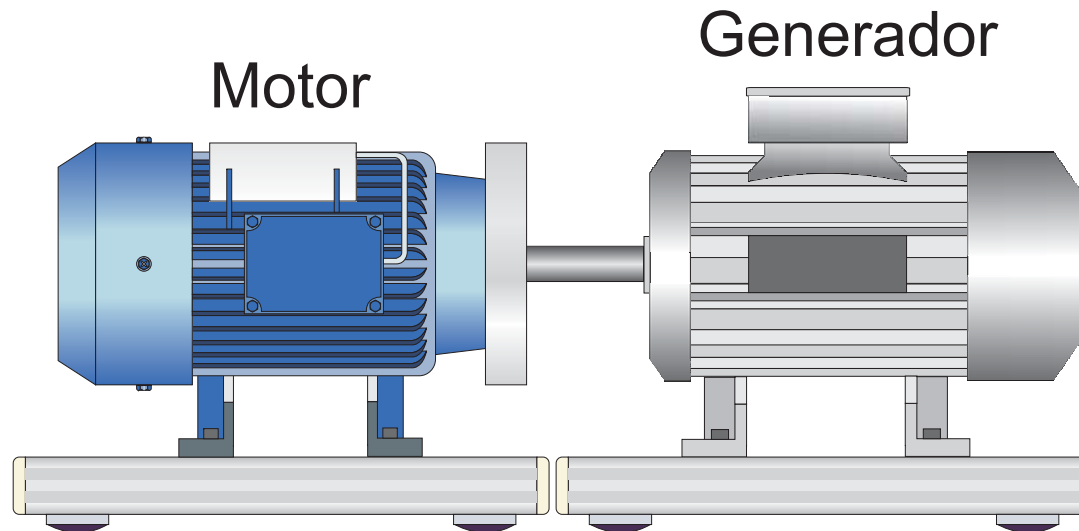
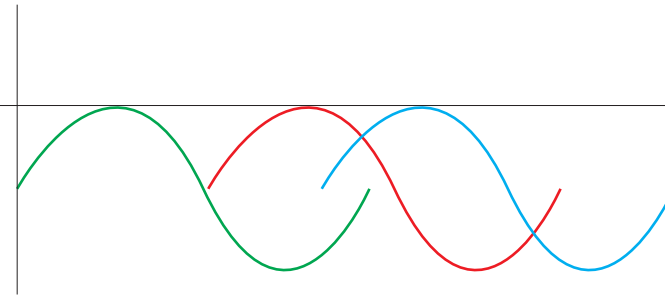

*Figura 8.75. Esquema general del frenado por contracorriente para motor con rotor en cortocircuito.*

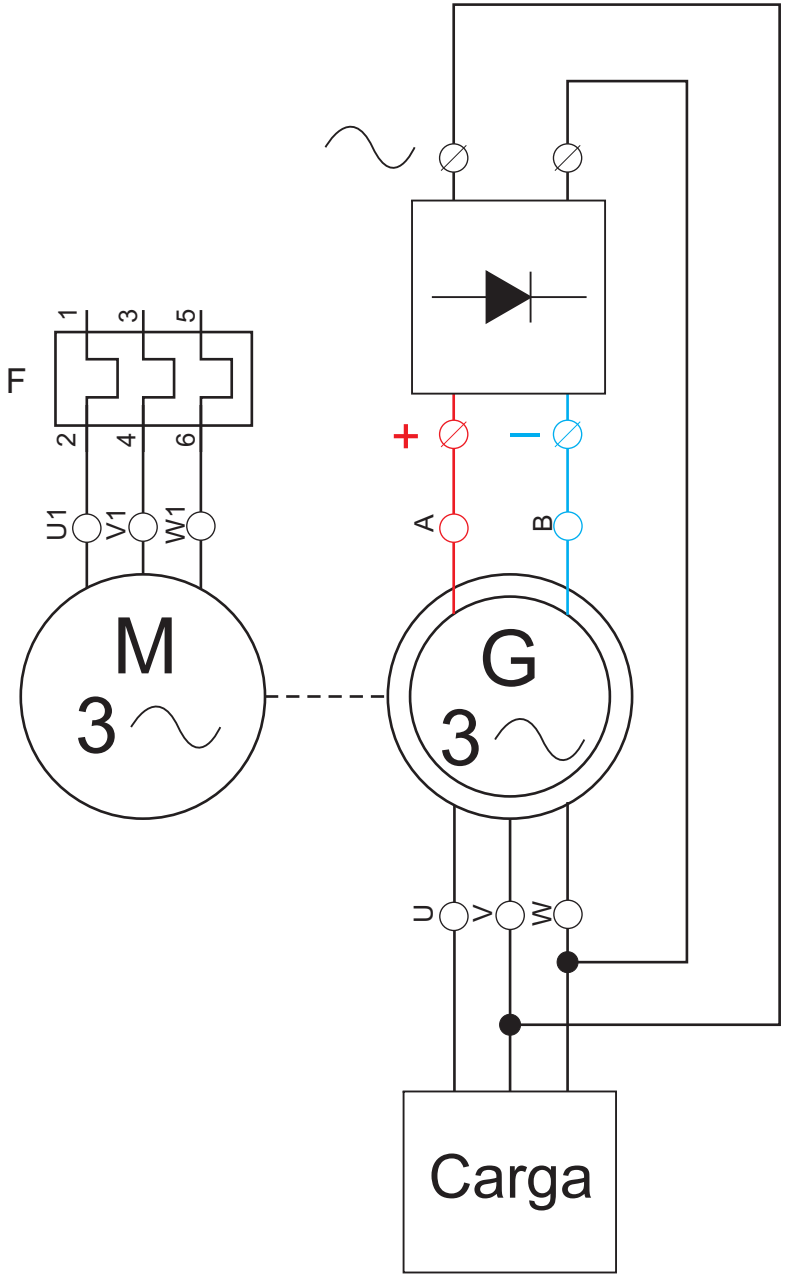
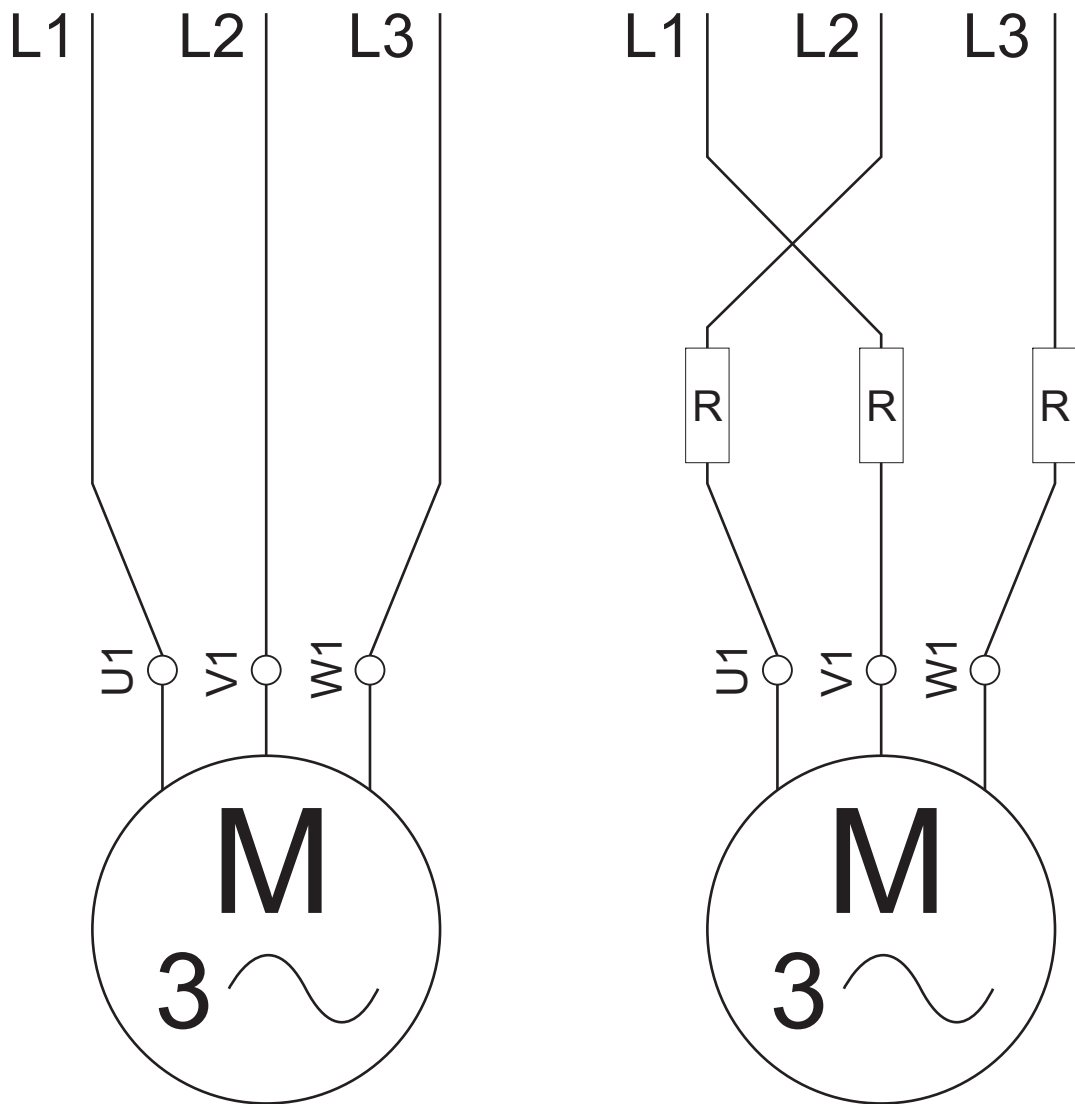
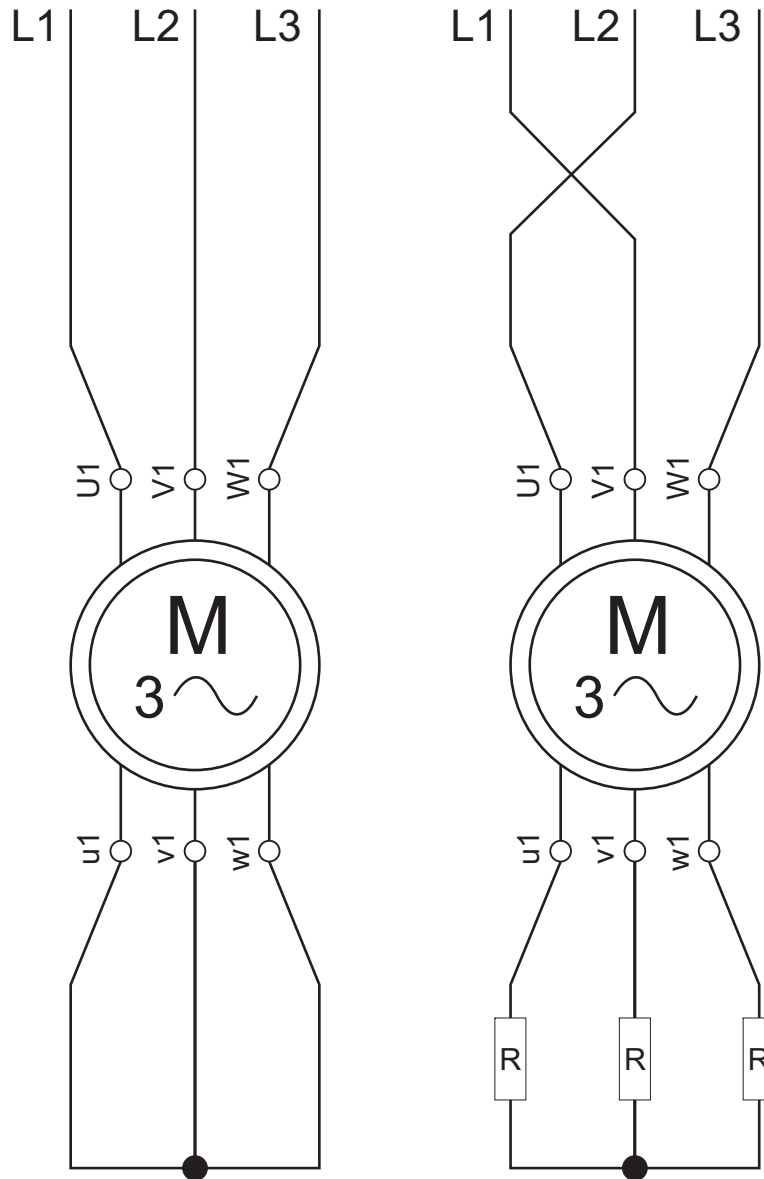

*Figura 8.76. Esquema general del frenado por contracorriente para motor con rotor bobinado.*

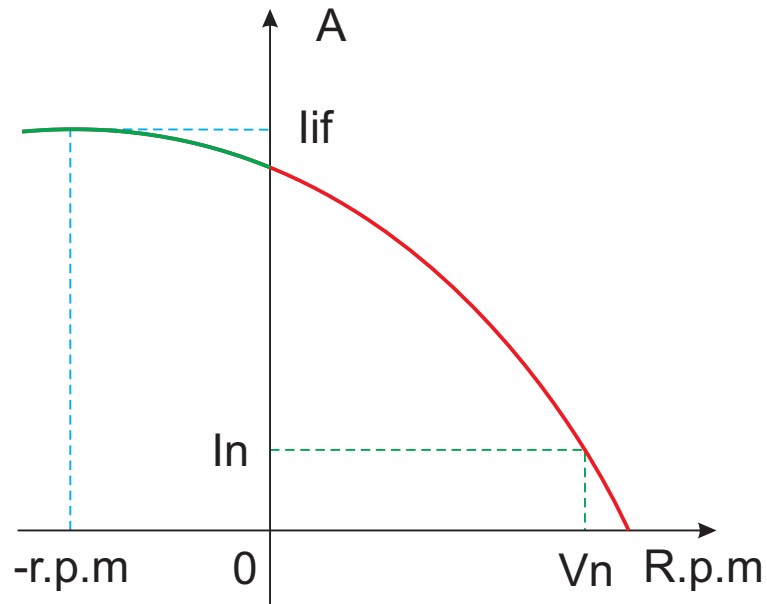

*Figura 8.77. Valores eléctricos en freno a contracorriente.*

Donde:

In. Intensidad nominal.

Vn. Velocidad nominal.

lif. Intensidad inicio de frenado.

lff. Intensidad fin de frenado.

— Intensidad cuando comienza el frenado a contramarcha.

— Intensidad fin de frenado.





Figura 8.78. Esquema de potencia.





Figura 8.79. Esquema general del frenado por contracorriente para motor con rotor en cortocircuito.

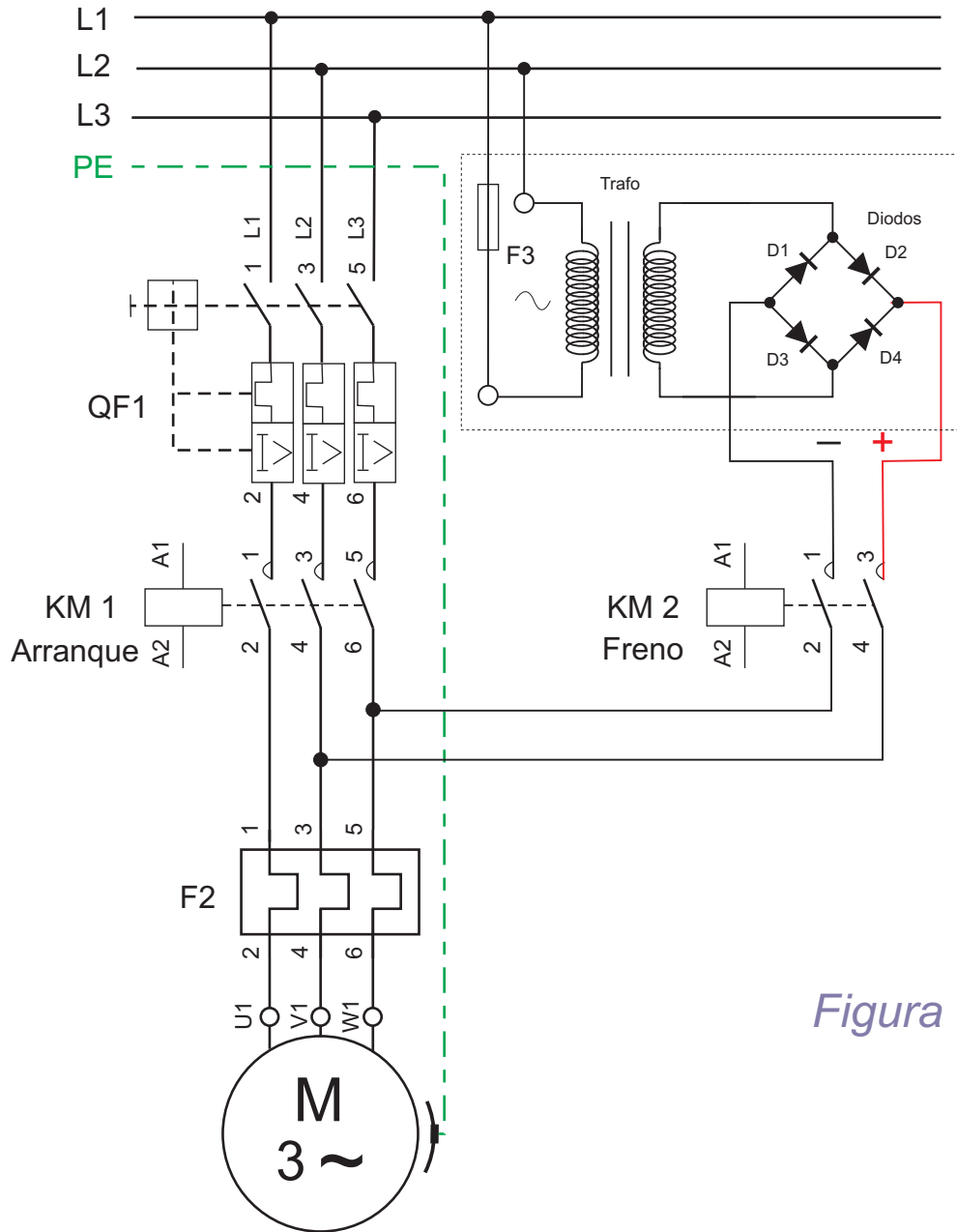

*Figura 8.80. Máquina con motor y embrague.*

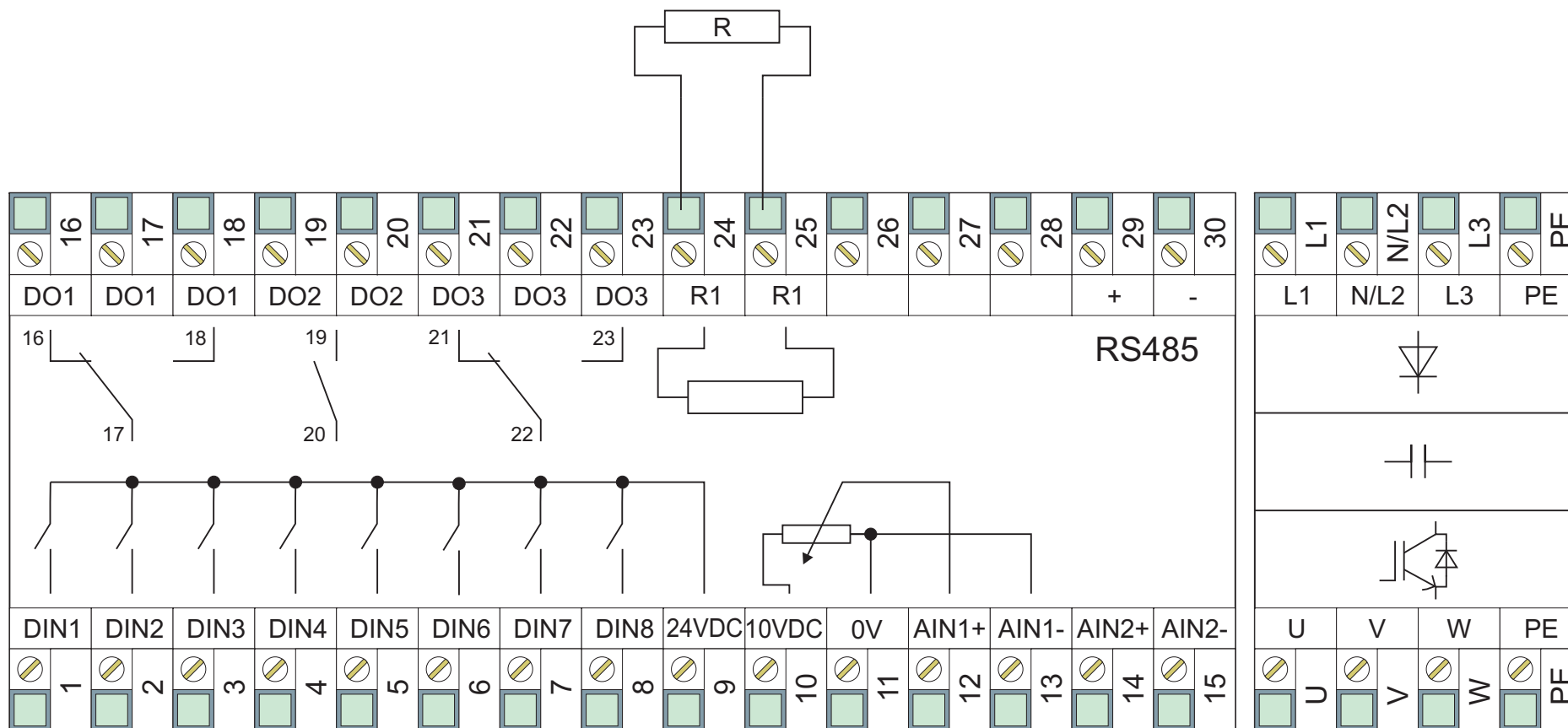
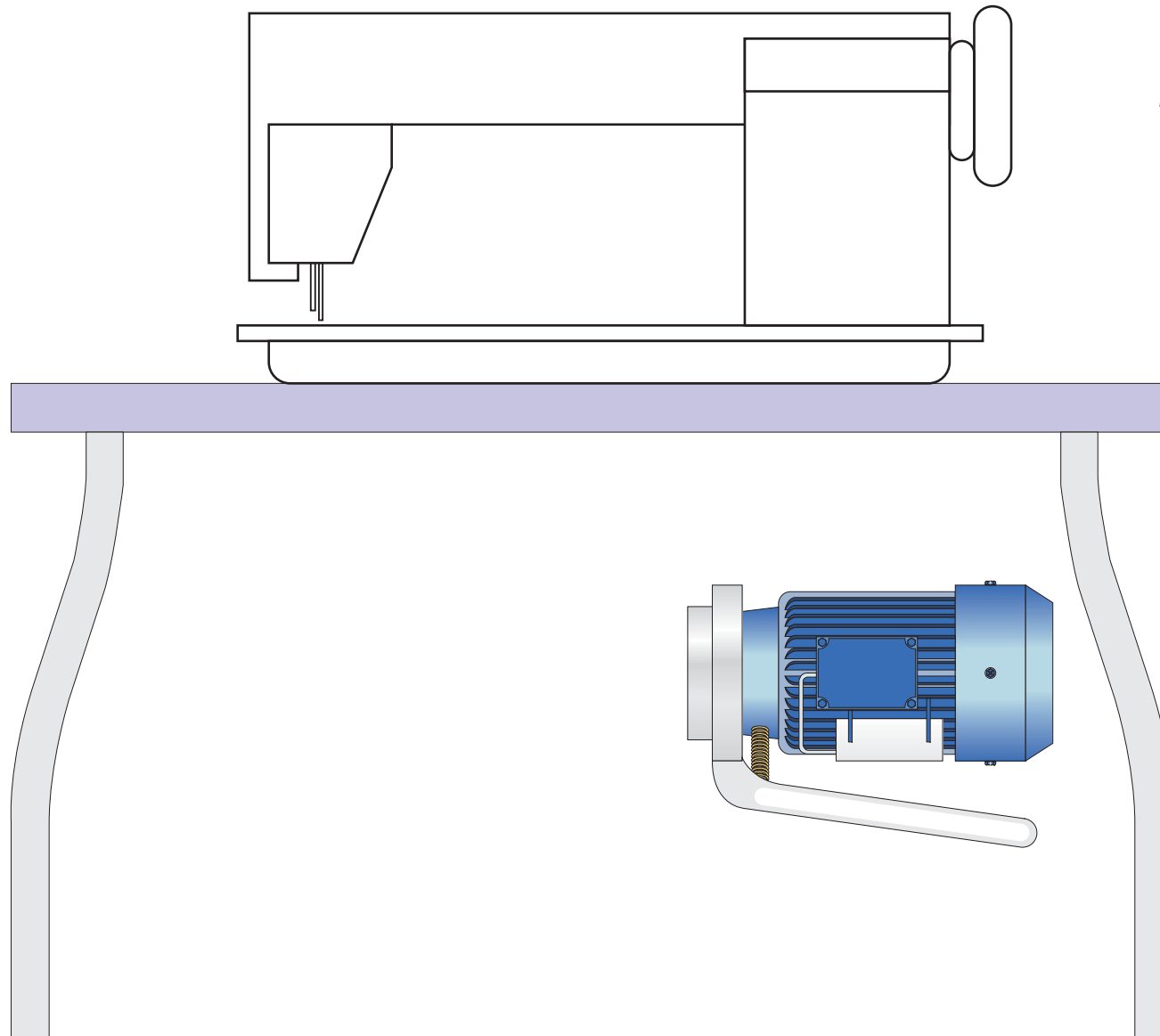